

Spinnit® FMMH-2.1C Hydraulic Paper Drill - Designed for Cancelling Decks of Playing Cards

USER'S MANUAL



Before operating this equipment, please read these instructions completely and keep these operating instructions for future reference.

Serial Number: _____
Date of Purchase: _____
Dealer: _____
Address: _____

Telephone Number: _____

Table Of Contents

1 - Introduction

- 1.1 Your New FMMH-2.1C Paper Drill..... Page 01
- 1.2 Shipping Damage Inspection..... Page 01

2 - Safety

- 2.1 Safety Instructions..... Page 02
- 2.2 Warning Labels..... Page 03
- 2.3 Grounding Instructions..... Page 04

3 - Setting Up Your Machine

- 3.1 Loose Items Inventory..... Page 05
- 3.2 Accessories Warning..... Page 05
- 3.3 Uncrating and Removing From the Pallet..... Page 06
- 3.4 Leveling The Machine..... Page 06
- 3.5 Adding the Oil..... Page 07
- 3.6 Installing and Positioning the Drill Strips..... Page 08
- 3.7 Attaching the Chip Bag..... Page 08
- 3.8 Electrical Instructions..... Page 08

4 - Operation

- 4.1 Protective Guard..... Page 09
- 4.2 Drill Bit Removal and Installation..... Page 09
- 4.3 Leveling the Drill Bits..... Page 10
- 4.4 Card Cage..... Page 11
- 4.5 Drilling Procedures..... Page 11
- 4.6 Tips on Drilling..... Page 12

5 - Maintenance

- 5.1 Safety..... Page 12
- 5.2 Annual Lubrication..... Page 12
- 5.3 Inspecting the Flex Drive..... Page 13
- 5.4 Changing the Hydraulic Oil..... Page 14

6 - Trouble Shooting Guide

- 6.1 Determining the Cause and Correction to Certain Problems..... Page 16

7 - Parts Diagrams

- 7.1 Side View..... Page 17
- 7.2 Head Assembly..... Page 18
- 7.3 Spindle and Chuck Assembly..... Page 19
- 7.4 Rear View..... Page 20
- 7.5 Parts List..... Page 21

1 - Introduction

1.1 - Your New FMMH-2.1C Paper Drill

- Thank you for your purchase of the Spinnit®FMMH-2.1C Paper Drill.
- We ask that you take a moment to fill in the serial number and other information on the front cover of the manual. Please keep this manual as a reference for future use.
- For parts and service, please contact the Lassco-Wizer Dealer from whom you purchased the machine. If you require assistance in locating a Lassco-Wizer Dealer please contact our customer service department at 585-436-1934. Please have the model of your machine and the serial number when you call.

1.2 - Shipping Damage Inspection

- Remove the machine from the carton and inspect for any shipping damage. If any damage is present, report the damage to the carrier immediately; failure to do so may void any warranties.

2 - Safety

2.1 - Safety Instructions

- All operators must read and understand the Users Manual including all safety instructions before using this equipment. Failure to fully understand the safety instructions can result in personal injury. If after reading the manual you are still uncertain about use, please contact the dealer from whom you purchased the machine for assistance. If you need contact information for a Service Technician nearest you please call 585-436-1934.
- SAFETY OF THIS EQUIPMENT IS THE RESPONSIBILITY OF THE USER(S).
- Please read and follow all warning labels on your machine.
- WEAR PROPER APPAREL. Do not wear loose clothing , gloves, neckties, rings, bracelets, or other jewelry which may get caught in moving parts. Non slip footwear is recommended. Wear protective hair covering to contain long hair.
- Keep hands clear while operating machine.
- ALWAYS USE SAFETY GLASSES. Also use face or dust mask if drilling operation is dusty. Everyday eyeglasses only have impact resistant lenses, they are NOT safety glasses.
- KEEP GUARDS IN PLACE and in working order.
- Always disconnect the power before servicing this machine. Service should only be performed by a QUALIFIED TECHNICIAN.
- Always turn the machine to off mode and wait for the drills to stop spinning before installing or removing drill bits. Keep hands away from drills when operating. PLEASE NOTE THAT THE DRILL BITS MAY BE HOT AFTER USE. PROCEED WITH CAUTION WHEN CHANGING THE DRILL BITS.
- DON'T USE IN DANGEROUS ENVIRONMENT. Don't use this machine in damp or wet locations, or expose it to rain. Keep work area well lighted.
- THIS MACHINE IS DESIGNED FOR ONE PERSON OPERATION. Never operate the machine with more than one person.

- KEEP CHILDREN AWAY. All visitors should be kept a safe distance from the work area.
- MAKE WORKSHOP KID-PROOF with padlocks or master switches.
- DON'T FORCE MACHINE. It will do the job better and safer at the rate for which it was designed.
- USE RIGHT MACHINE. Don't force tool or attachment to do a job for which it was not designed.
- MAINTAIN MACHINE WITH CARE. Keep tools sharp and clean for best and safest performance. Follow instructions for lubricating and changing accessories.
- REMOVE ADJUSTING KEYS AND WRENCHES. Form habit of checking to see that keys and adjusting wrenches are removed from machine before turning it on.
- KEEP WORK AREA CLEAN. Cluttered areas and benches invite accidents.
- DISCONNECT MACHINE before servicing; when changing accessories, such as drill bits, drill blocks, and the like.
- REDUCE THE RISK OF UNINTENTIONAL STARTING. Make sure the power switch is in the off position before plugging in.
- USE RECOMMENDED ACCESSORIES. Consult the user's manual for recommended accessories. The use of improper accessories may cause risk of injury to persons.
- NEVER STAND ON MACHINE. Serious injury could occur if the machine is tipped.
- DON'T OVERREACH. Keep proper footing and balance at all times.
- CHECK DAMAGED PARTS. Before further use of the machine, a guard or other part that is damaged should be carefully checked to determine that it will operate properly and perform its intended function--check for alignment of moving parts, binding of moving parts, breakage of parts, mounting, and any other conditions that may affect its operation. A guard or other part that is damaged should be properly repair or replaced.
- NEVER LEAVE MACHINE RUNNING UNATTENDED. TURN POWER OFF. Don't leave machine until it comes to a complete stop.

2 - Safety

2.2 - Warning Labels



- **WARNING: DO NOT EXPOSE TO RAIN OR USE IN DAMP LOCATIONS.**



⚠ WARNING

Read and understand operator's manual and all other safety instructions before using this equipment

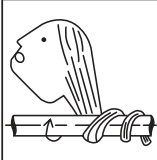

⚠ WARNING

Entanglement hazard.
Rotating parts.
Do NOT operate with exposed long hair, jewelry or loose clothing.



⚠ WARNING

Moving parts can crush and cut
Keep hands clear while operating machine.



⚠ WARNING

Risk of eye injury.
Wear eye protection.

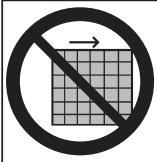

⚠ WARNING

Risk of Injury.
Do NOT operate without guards in place.

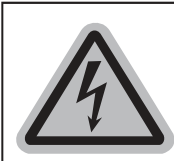

⚠ DANGER

Severe shock hazard.

Only authorized personnel may service this equipment.
Turn power OFF before entry.



⚠ CAUTION

For continued protection against risk of fire, replace **ONLY** with a fuse of the same type and having the same electrical rating.

2.3 - Grounding Instructions

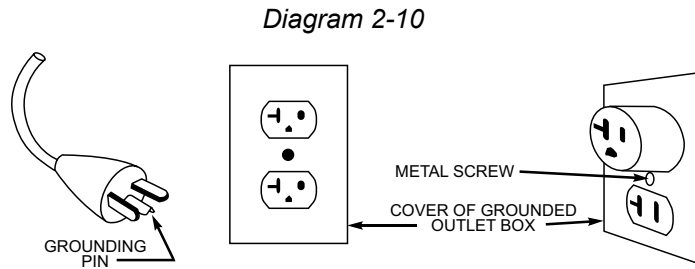

- In the event of a malfunction or breakdown, grounding provides a path of least resistance for electric current to reduce the risk of electric shock. This tool is equipped with an electric cord having an equipment-grounding conductor and a grounding plug. The plug must be plugged into a matching outlet that is properly installed and grounded in accordance with all local codes and ordinances.
- **DO NOT MODIFY THE PLUG PROVIDED.** If it will not fit the outlet, have the proper outlet installed by a **QUALIFIED ELECTRICIAN**.
- Improper connection of the equipment-grounding conductor can result in a risk of electric shock. The conductor with insulation having an outer surface that is green with or without yellow stripes is the equipment-grounding conductor. If repair or replacement of the electric cord or plug is necessary, do not connect the equipment-grounding conductor to a live terminal. Check with a **QUALIFIED ELECTRICIAN** or service personnel if the grounding instructions are not completely understood, or if in doubt as to whether the tool is properly grounded. Use only 3-wire extension cords that have 3-prong grounding plugs and 3-pole receptacles that accept the machine's plug.
- This machine is intended for use on a circuit that has an outlet that looks like the one illustrated in diagram 2-10. The machine has a grounding plug that looks like the plug illustrated in diagram 2-10. Make sure the machine is connected to an outlet having the same configuration as the plug. No adapter is available or should be used with this machine. If the machine must be reconnected for use on a different type of electric circuit, the reconnection should be made by qualified service personnel; and after reconnection, the tool should comply with all local codes and ordinances.

3 - Setting Up Your Machine

3.1 - Loose Items Inventory

- Please remove and inspect the following items:

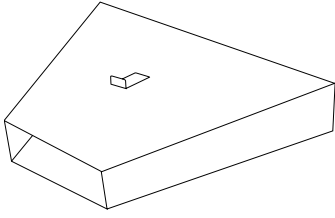

FMM6-651A: Master Chip Chute (1)
(this item may be installed)

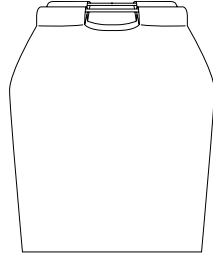

FMM6-652A: Chip Bag Assembly (1)

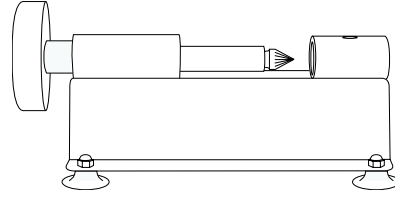

MS-1: Drill Sharpener (1)

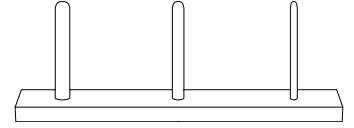

CC-2: Chip Clearer (1)

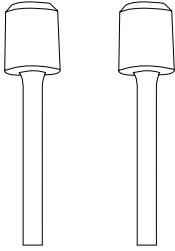

5/16" Hollow Drill Bits (2)
(these items may be installed)



EBM-32: Chuck Release Key (1)

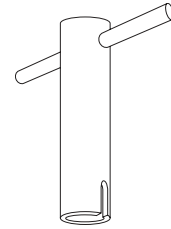

FMM9-957A: Spindle Rotation Tool (1)

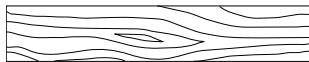

HL3G06: Drill Strips (3)



HEX-18: Hex Wrench 1/8" (1)

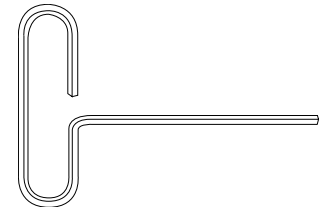

HEX-732-T: Hex Wrench 7/32" T Style (1)

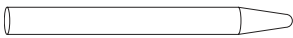

EBM-41: Sharpening Stone (1)



DRILL-EASE: Drill Bit Lubricant (1)



FMH-2030: Hydraulic Oil (1)

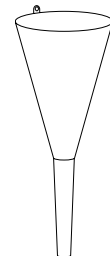

HG07: Plastic Funnel (1)

3.2 - Accessories Warning

- **USE RECOMMENDED ACCESSORIES.** Only use accessories approved by a Lassco-Wizer. The use of improper accessories may cause risk of injury to persons.

3 - Setting Up Your Machine

3.3 - Uncrating and Removing From the Pallet

- 3.3.1** Remove the wooden framing around the outside box.
- 3.3.2** Remove the box up and over the machine.
- 3.3.3** Remove the four (4) 5/16" bolts which are securing the machine to the pallet: access through the rear of the machine using a 5/16" wrench (not provided) as shown in diagram 3-10. Discard the four (4) 5/16" bolts.
- 3.3.4** Remove the FMMH-2.1C from the pallet carefully "stepping" it off the edge. DO NOT drop the machine. DO NOT lift by the table. Two people may be needed to remove the machine from the pallet safely.

Diagram 3-10

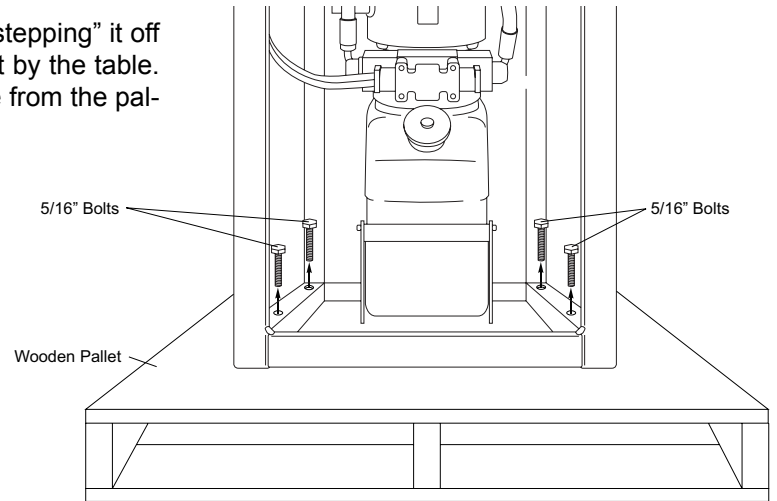

3.4 - Leveling The Machine

- 3.4.1** Set the machine down in its desired location and determine if the machine is level, making sure that it does NOT rock in any direction. If it does, determine which Leveling Feet need to be adjusted and whether they need to be adjusted up or down.
- 3.4.2** If adjustment is needed, start by loosening the four (4) nuts which are accessed through the rear of the machine.
- 3.4.3** Next adjust the four (4) Leveling Feet by screwing them clockwise to raise them or counter-clockwise to lower. After each adjustment set the machine down completely to verify that the machine no longer rocks. Continue adjustment as needed until the machine sits securely in place. Tighten the four (4) nuts down to secure the position of the Leveling Feet.

Diagram 3-20

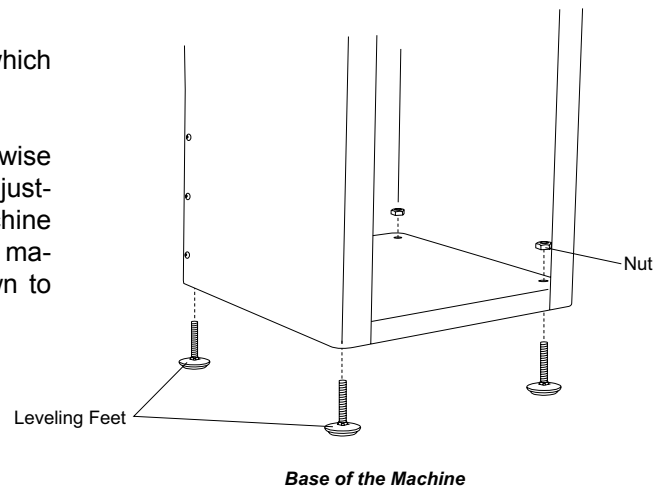

3 - Setting Up Your Machine

3.5 - Adding the Oil

- 3.5.1** Remove the back cover by unscrewing the eight (8) hex screws that hold it in place.
- 3.5.2** Remove the Cap on the Oil Tank.
- 3.5.3** Insert the Plastic Funnel, included with the machine, into the Oil Tank and, using the new batch of Hydrol HL Oil (HL3HY) included with the machine, fill the tank with 1-1/2 gallons or until the Oil Tank is approximately 3/4 filled with oil.
- 3.5.4** Replace the Cap making sure it is sealed securely.
- 3.5.5** Replace the Back Cover by securing the eight (8) hex screws that hold it in place.
- 3.5.6** After adding the oil it will be necessary to work the air out of the system. This is done by turning the power to the Hydraulic Motor on and activating the foot pedal to raise and lower the table. Air in the hydraulic lines may make the table motion erratic. Continue raising and lowering the table until the machine responds in the usual way indicating the all the air has been bled out of the hydraulic lines.

Diagram 3-25

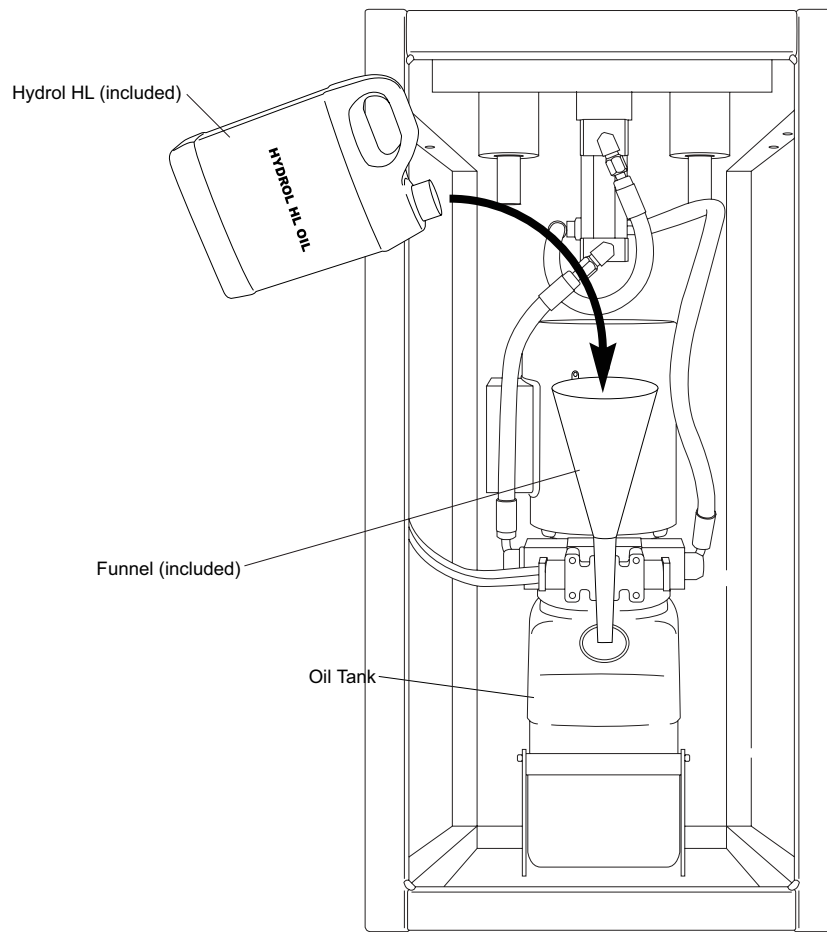

3 - Setting Up Your Machine

3.6 - Installing and Positioning the Drill Strips

3.6.1 Slide the Drill Strip(s) (HL3G06) into the slot located on the Table Assembly as shown in diagram 3-40. Position the Drill Strip(s) under the Card Cage so that they are directly beneath the Drill Bits when the Table rises. It is recommended that the drill strips be rotated and changed regularly as they wear. For additional information on Drill Strips see section 4.5 and section 4.6.

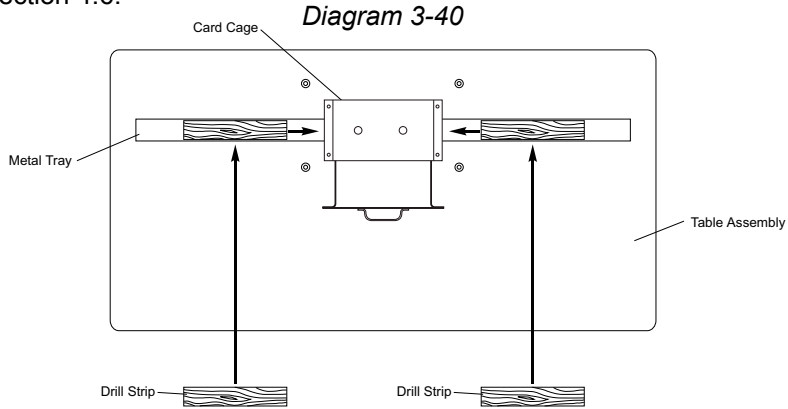

3.7 - Attaching the Chip Bag

3.7.1 Attach the Chip Bag (FMM6-652A) to the machine by stretching the mouth of the bag over the Master Chip Chute and hooking the aluminum bar onto the bracket located on the top flat portion of the master chip chute as shown. Please note that you must empty this bag as needed to avoid clogging.

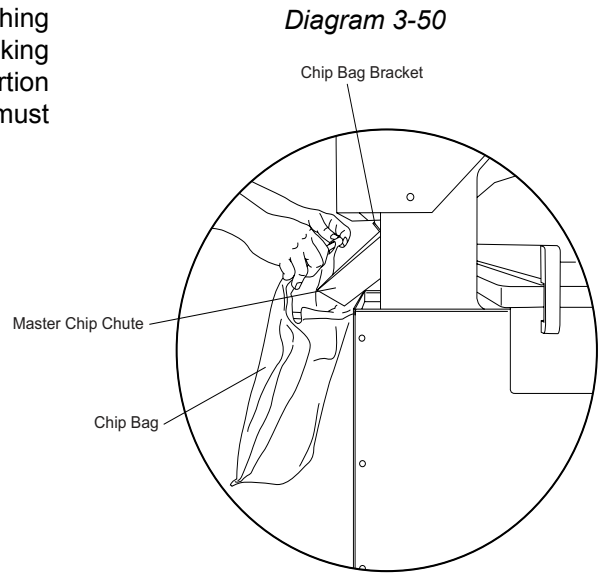

3.8 - Electrical Instructions

3.8.1 Your FMMH-2.1C comes with an electrical cord containing the plug to fit into standard grounded 115V outlets. This machine has a combined full load draw of 18.8 Amps and requires a 20 Amp Circuit.

3.8.2 Making sure that nothing is interfering with the drill bits, plug the cord set into a grounded 115V outlet. To turn the Drill Motor on, face the machine and press the Rocker Switch on the left-hand side labeled "Drill Motor." To turn the Table Motor on, face the machine and press the Rocker Switch on the right-hand side labeled "Table Motor."

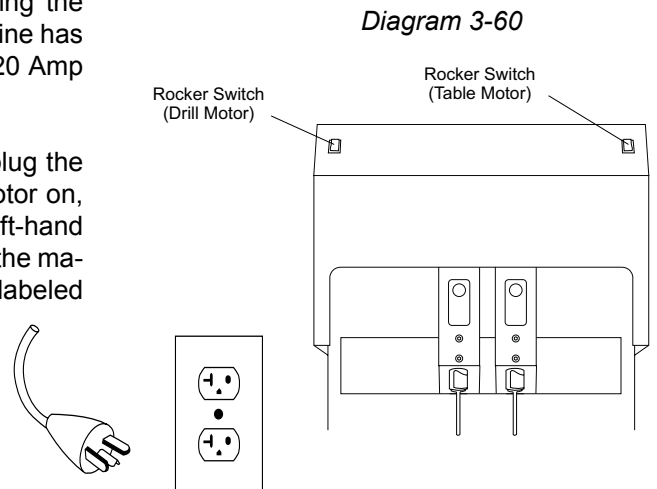

4 - Operation

4.1 - Protective Guard

- 4.1.1** Your FMMH-2.1C comes with a protective guard installed. DO NOT operate this machine without the guard in place.
- 4.1.2** Please note that when you are performing certain operations such as removing and installing drill bits, you will need to move the guard out of the way. Making sure the power to the machine is disconnected or locked-out, push the guard up and hold in place while performing necessary operations or maintenance. The protective guard should not be removed during operation.

Diagram 4-10

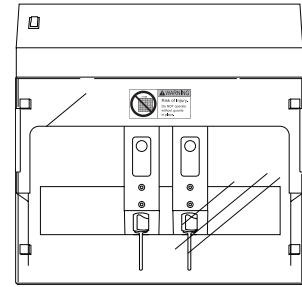

4.2 - Drill Bit Removal and Installation



CAUTION: DRILL BITS MAY BE HOT AFTER USE. ALLOW DRILL BITS TO COOL DOWN BEFORE TOUCHING.



BEFORE REMOVING OR INSTALLING THE DRILL BITS, DISCONNECT OR LOCK-OUT THE POWER SUPPLY TO THE DRILL MOTOR.

- 4.2.1** We recommend using a piece of card stock on the Table when leveling the drill bit to avoid drilling into the drill strip. This will lengthen the life of your drill bits and keep them sharper.
- 4.2.2** Remove the hole guard which is attached to the chuck. This is done by grasping the tab and sliding the guard off.
- 4.2.3** Using the Chuck Release Key (EBM-32), insert the tapered end facing down into the chuck hole. In a clockwise motion turn the Chuck Release Key 45 degrees. The drill bit will slide out of the chuck. It is recommended that you hold onto the drill bit so that it does not drop out of the chuck damaging the tip.
- 4.2.4** To install a drill bit, grasp the drill bit, and being careful to keep it straight, press it up into the chuck.
- 4.2.5** Seat the drill bit by using a stack of scrap paper. Set the scrap on the table. Lower the table lift speed by turning the Table Adjustment Knob (see section 4.9). Step on the foot pedal slowly raising the table toward the Drill Bit. Put light pressure on the hollow Drill Bit seating it firmly in place.
- 4.2.6** Remove the scrap paper and turn the machine on to check the concentricity of the bit. If the bit is not concentric, remove it and repeat steps 4.2.2 through 4.2.5 until it is concentric.
- 4.2.7** When the drill bit is correctly installed replace the hole guard back onto the chuck to protect debris from clogging the chuck.

Diagram 4-20

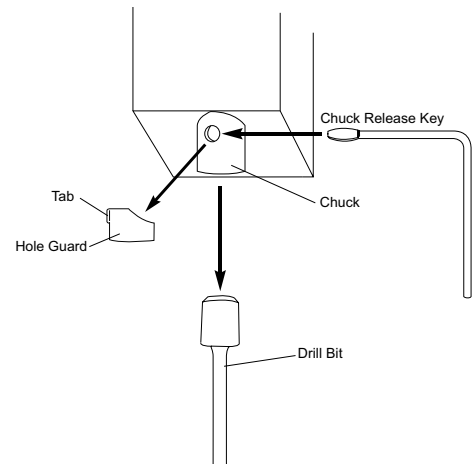
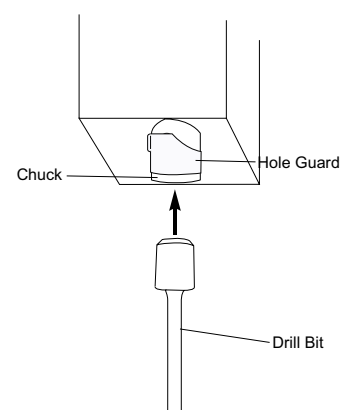

Diagram 4-30



4 - Operation

4.3 - Leveling the Drill Bits



BEFORE LEVELING THE DRILL BITS, MAKE SURE THAT THE DRILL MOTOR SWITCH IS IN THE OFF POSITION.

- 4.3.1** We recommend using a piece of card stock on the Table when leveling the drill bits to avoid drilling into the drill strip. This will lengthen the life of your drill bits and keep them sharper.
- 4.3.2** Remove one (1) of the two (2) Access Guard Screws using the 1/8" Hex Wrench (HEX-18). Swing the Access Guard as shown in diagram 4-40 to gain access to the motor shaft.
- 4.3.3** Insert the Spindle Rotation Tool (FMM9-957A) into the end of the motor shaft through the opening in the top of the machine shroud until the notch in the Spindle Rotation Tool fits into the keyway securely.
- 4.3.4** Swing the access cover located on the front of the heads to one side allowing access to the spindle and chuck.
- 4.3.5** Turn the Spindle Rotation Tool by hand until the Insert Retainer Screw can be seen in the opening.
- 4.3.6** Turn the rocker switch labelled Table Motor on. Stepping on the foot pedal, raise the table so that it meets the bottom of the pressure foot assembly. By keeping the foot pedal activated during steps 4.3.7 through 4.3.8 the table will stay in the full upright position.
- 4.3.7** Using the 7/32" Hex Wrench (HEX-732-T), loosen the insert retainer screw approximately one half turn (loosening too much may cause the insert retainer screw to come out completely). Retighten the insert retainer screw until it is snug but not tight; this will allow you to raise or lower the chuck without too much play. Hold onto the Spindle Rotation Tool to prevent the belts from turning. Lower the height of the Chuck by turning it counter-clockwise. Raise the height of the Chuck by turning it clockwise.
- 4.3.8** When the drill bit is just touching the drill strip, re-tighten the insert retainer screw. This may require you to turn the Spindle Rotation Tool until the Insert Retainer Screw is again accessible through the opening.
- 4.3.9** Lower the table
- 4.3.10** Repeat steps 4.3.3 through 4.3.9 on the remaining Drill Bits so that they are all level with each other.
- 4.3.11** REMOVE THE SPINDLE ROTATION TOOL FROM THE MOTOR SHAFT. Leaving this attached can cause injury to the user as it can fly out of the machine upon startup.
- 4.3.12** Replace all the Access covers and Access Guards so that they cover the motor shaft opening and the retainer screw openings.

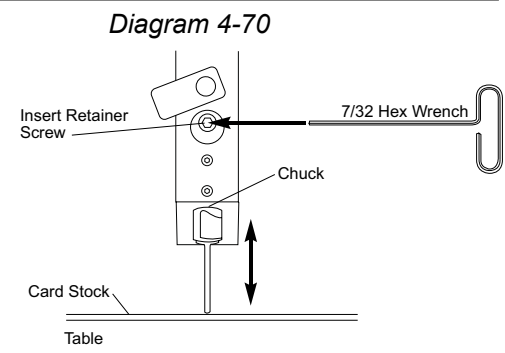
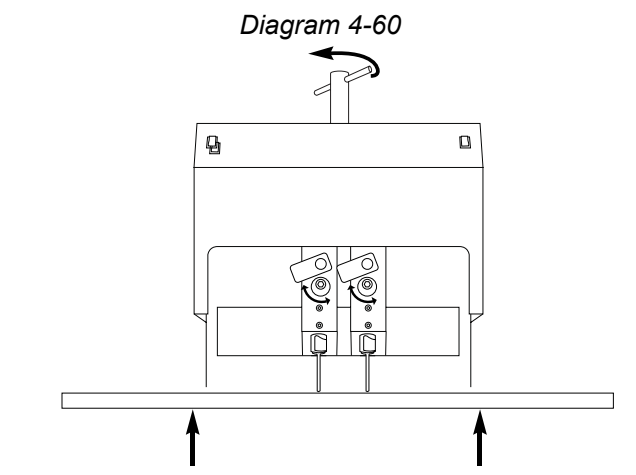
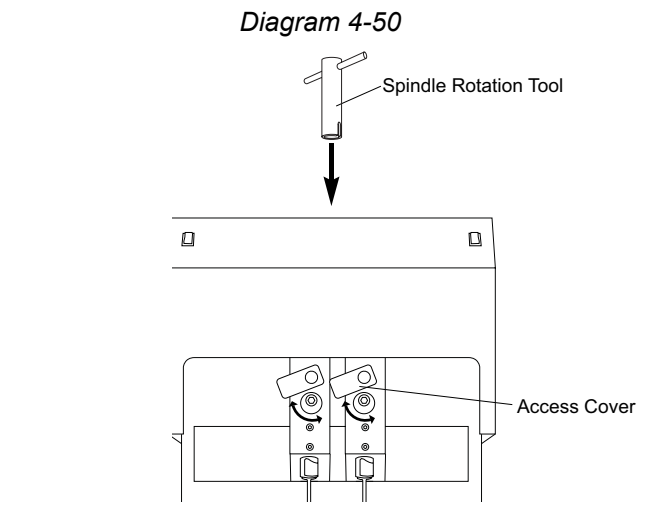
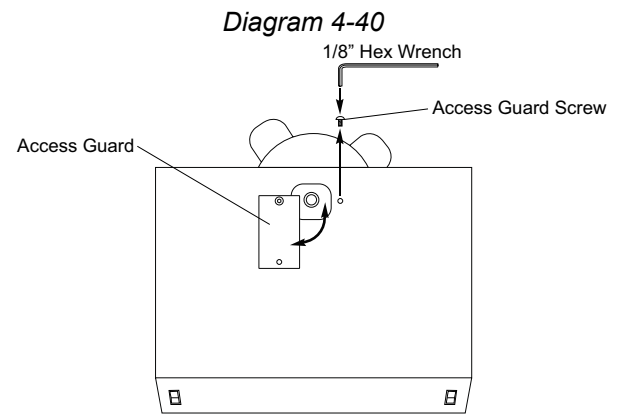

4 - Operation

4.4 - Card Cage

4.4.1 The Card Cage is designed to hold six (6) decks of playing cards at a time (three (3) decks high and two (2) decks wide). Pull out the Card Cage Drawer as shown in diagram 4-60; insert six decks of cards as shown and close the Card Cage Drawer. Proceed with drilling. After cards have been drilled, remove card decks.

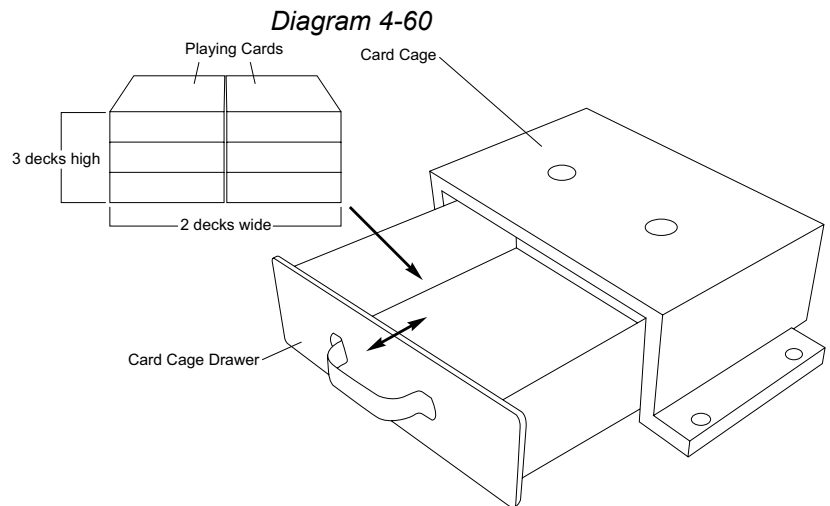

4.5 - Drilling Procedures

4.5.1 After all your adjustments are made as desired, position the Table in its primary position. Set the product to be drilled on the table and make sure it is secure using the Paper Side Stops. To drill, step down on the Foot Pedal and hold, raising the Table up to meet the drill bits. Make sure the Table rises fully allowing the drill bits to drill through the product. When the drill bits have penetrated through the entire stack of product, release the Foot Pedal, which allows the table to return to its lowered position.

4.5.2 It is important you do not drill too slow or too fast. If you drill too slow you can burn the paper leaving undesired marks. If you drill too fast, the drill bits will act more like a punch and they will break.

4.5.3 If your Table rises too slow: increase the speed of your Table rise by turning the Table Adjustment Knob, located just under the Table on the front of the machine, counterclockwise.

4.5.4 If your Table rises too fast: decrease the speed of your Table rise by turning the Table Adjustment Knob clockwise.

4.5.5 Different product requires different speeds. It is always recommended to drill through a test stack of the product until the operator is confident of the required speed.

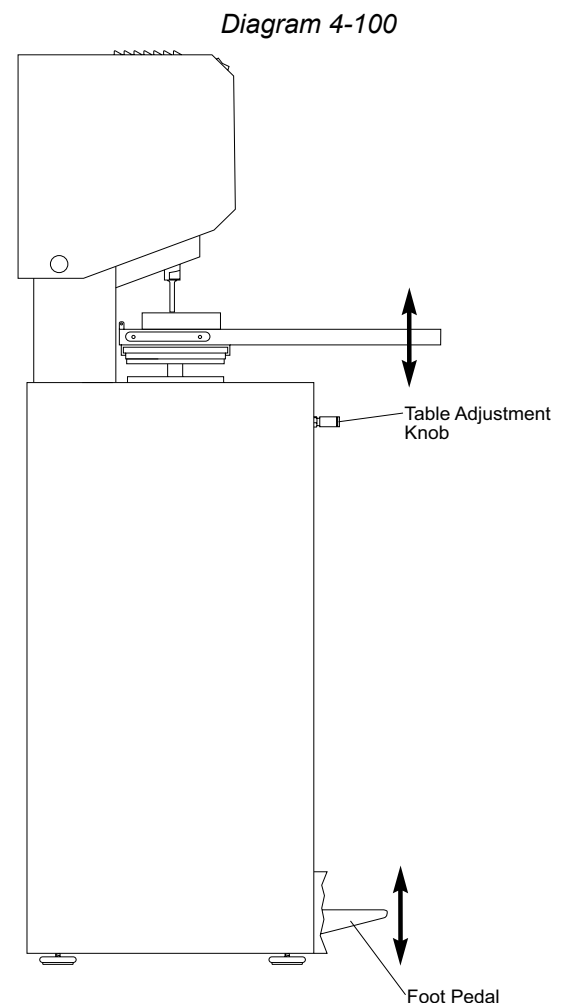

4 - Operation

4.6 - Tips on Drilling

- 4.6.1** Use a sharp drill bit at all times... Using the MS-1 drill bit sharpener, sharpen your drill bits regularly. Apply light pressure when sharpening. Too much pressure may cause flaring of the tip. (Once a drill bit has a flared tip, it becomes defective.)
- 4.6.2** Sharpening Stone... Use to debur the outside cutting edge of the drill bits for better performance.
- 4.6.3** Lubricate drill bits occasionally... Use Drill-Ease or Spin-Eze. While the drill is running, simply touch the Drill-Ease stick to the drill bit or brush on the Spin-Eze. Drill through scrap to remove any excess. This will allow for a smoother cut.
- 4.6.4** Drill Strips...When drilling, a drill bit must stop slightly above the drill strip. Replace worn out drill strips regularly to ensure proper drilling.

5 - Maintenance

5.1 - Safety



ALWAYS DISCONNECT THE POWER BEFORE PERFORMING THE FOLLOWING MAINTENANCE ON THIS MACHINE. MAINTENANCE SHOULD ONLY BE PERFORMED BY A QUALIFIED TECHNICIAN.



KEEP HANDS CLEAR WHILE PERFORMING MAINTENANCE ON THIS MACHINE. MOVING PARTS CAN CRUSH AND CUT.

5.2 - Annual Lubrication

- 5.2.7** Making sure the machine is unplugged and after disconnecting the electrical wiring to the Switch on the shroud, remove the shroud by lifting straight up to clear the drive mechanism making sure the Traverse Locks are disengaged.

Diagram 5-40

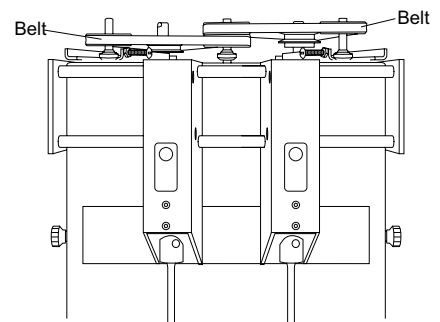

5 - Maintenance

5.3 - Inspecting the Flex Drive

5.3.1 Inspecting the Flex Drive on your FMMH-2.1C should be done at least once every 12 months; however, it may be necessary to check this more often if problems with the rotation of the spindles is noticed. Belt shavings are normal for new adjusted belts, but contact a service technician if it becomes excessive.

5.3.2 Inspect the Belts for wear and the proper tension. The tension should be adjusted to an approximate 1/2" gap between a straight edge placed from the outside edge of the Idler Pulley to the outside edge of the Outside Pulley with the pulleys located one behind the other. Depress the belt halfway between the two pulleys and measure the distance between the straight edge and the belt depression.

Diagram 5-40

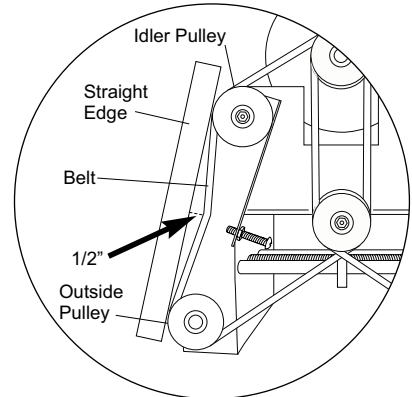

Belt Tension

5.3.3 The belts can be adjusted by loosening the Lock Nut on the Belt Adjustment Screw located on the front portion of the Flex Drive Pivot Assembly and turning the screw clockwise to tighten the belt and counterclockwise to loosen the belt. After the belt has been properly adjusted, re-tighten the Lock Nut.

Diagram 5-50

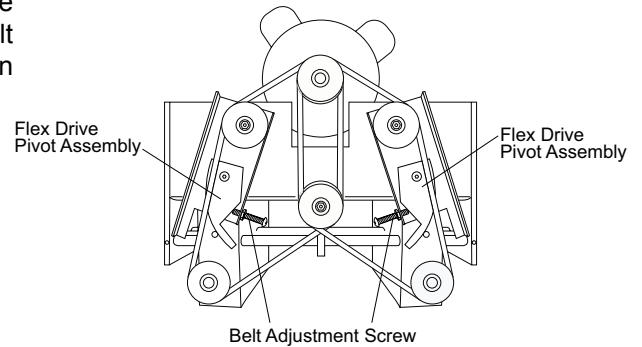

5.3.4 Visually check the Flex Drive Pivot Assembly for unusual wear. Check the Pivot Assembly bolts and tighten if necessary.

Diagram 5-60

5.3.5 Be sure the wiring is clear of all moving components and is properly attached when replacing the Shroud.

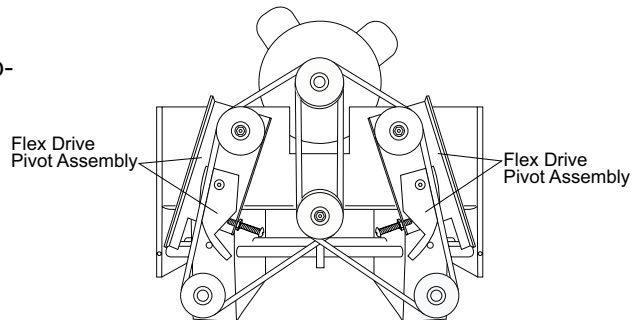

5 - Maintenance

5.4 - Changing the Hydraulic Oil

- 5.4.1** When using Lassco Wizer Hydrol HL, the Hydraulic Oil should be changed every 2100 Machine Hours. Machine Hours are defined as the period of time that the Table Motor is turned on and pumping oil, regardless of being operated or not (Even when not drilling, the Table Motor is pumping oil continuously).
- 5.4.2** If an equivalent oil (other than Hydrol HL) is used, this maintenance schedule may vary, depending on the manufacturer's specifications. Some hydraulic oils break down when their temperature exceeds 120°F (48.9°C). Hydrol HL will maintain its consistency until it reaches 210°F (98.9°C)
- 5.4.3** Access the Oil Tank by removing the eight (8) hex screws on the rear of the machine which hold the Back Cover in position. Remove the back cover.
- 5.4.4** To drain the Hydraulic Oil: Remove the Cap by twisting it counterclockwise. Drain the Hydraulic Oil using either a pump system to pump the oil out of the machine, or use a siphon system to drain out the oil. It is important to remove as much of the oil as possible.
- 5.4.5** Discard the used hydraulic oil making sure to follow all local regulations when disposing.

Diagram 5-70

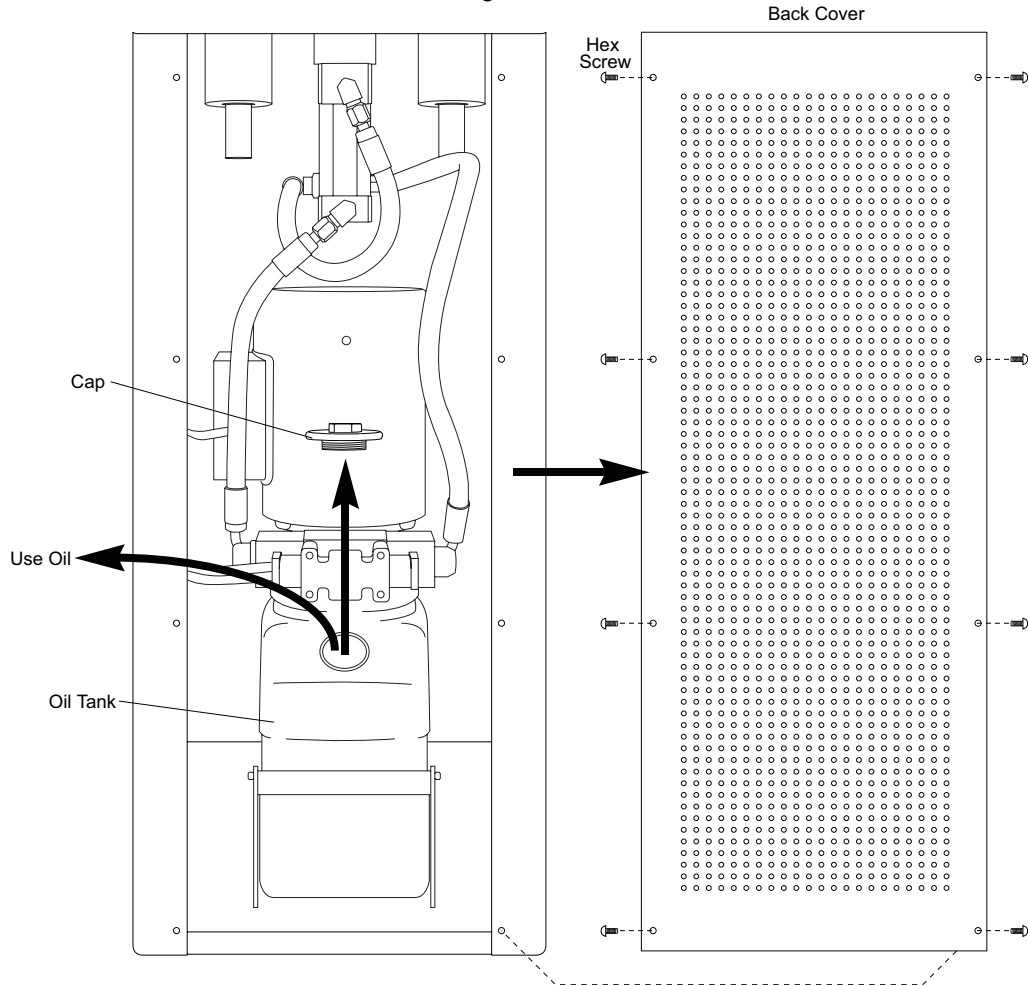

5 - Maintenance

5.4 - Changing the Hydraulic Oil

- 5.4.6** Insert the included Plastic Funnel into the Oil Tank and, using a new batch of Hydrol HL Oil (HL3HY) or an equivalent brand, fill the tank with 1-1/2 gallons or until the Oil Tank is approximately 3/4 filled with oil.
- 5.4.7** Replace the Cap making sure it is sealed securely.
- 5.4.8** Replace the Back Cover by securing the eight (8) hex screws that hold it in place.
- 5.4.9** After changing the oil it will be necessary to work the air out of the system. This is done by turning the power to the Hydraulic Motor on and activating the foot pedal to raise and lower the table. Air in the hydraulic lines may make the table motion erratic. Continue raising and lowering the table until the machine responds in the usual way indicating all the air has been bled out of the hydraulic lines.

Diagram 5-80

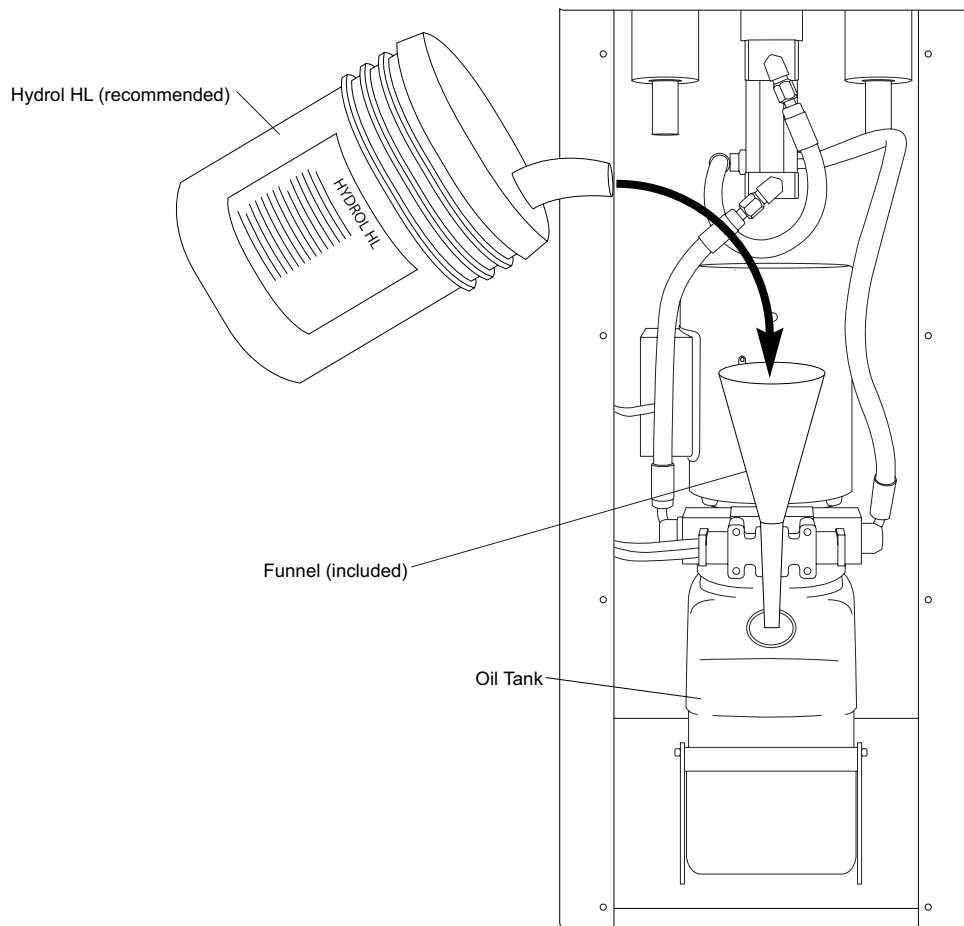

6 - Trouble Shooting Guide

6.1 - Determining the Cause and Correction to Certain Problems

Problem	Cause	Correction
Drill bit not concentric.	Foreign material in chuck or in drill plug.	Inspect and clean.
	Drill bit is bent.	Replace drill bit.
	Drill bit not seated in chuck properly.	Re-insert drill bit correctly. See <i>Operating Instructions</i> .
	Chuck is not tight to spindle.	Tighten set screw.
Drill bit not drilling.	Drill bit plugged.	Remove and clear chips. Check for other foreign matter.
	Drill bit dull.	Sharpen drill bit.
	Note: In extreme conditions, the drill chuck and/or chip chute may be plugged. Remove the drill bit, loosen the chip chute, pull down, and clean. See <i>Operating Instructions</i>	
Uncommon metallic sounds from under the shroud.	The Drive Pulley is loose.	Adjust the Drive Pulley to the proper height and tighten or replace the Set Screw.
	The Needle Bearings on the Idler Pulley(s) are not lubricated.	Lubricate the Needle Bearings as needed.
Machine vibrates, wobbles, resonates, etc.	The machine is not level on the floor.	Use the leveling feet to make the machine level on the floor. See <i>Setting Up Your Machine</i> .
	The machine is located directly on a concrete floor.	Place a rubber mat or carpet under the machine.
	Drill bit(s) are not concentric.	Re-install drill bit(s) until they are concentric. See <i>Operating Instructions</i> .
The drill bit(s) are drilling into the drill strip or they are not drilling through the bottom sheet of the product you are drilling.	Drill bit(s) are not adjusted properly to the card stock/card stock not used.	Adjust your drill bit(s) per <i>Operating Instructions</i> .
	The Chuck(s) were not tightened after adjustment.	Re-adjust and tighten.
The drill bit(s) do not rotate when the motor is turned on.	A Drive Belt is broken on the Flexible Drive System.	Replace the broken belt. See <i>Maintenance</i> .
	A Drive Belt is loose on the Flexible Drive System.	Tighten the loose belt. See <i>Maintenance</i> .
	An Insert Retainer Screw is hitting the inside of the Chuck Housing.	Adjust the Chuck and tighten the Insert Retainer Screw.

7 - Parts Diagrams

7.1 - Side View

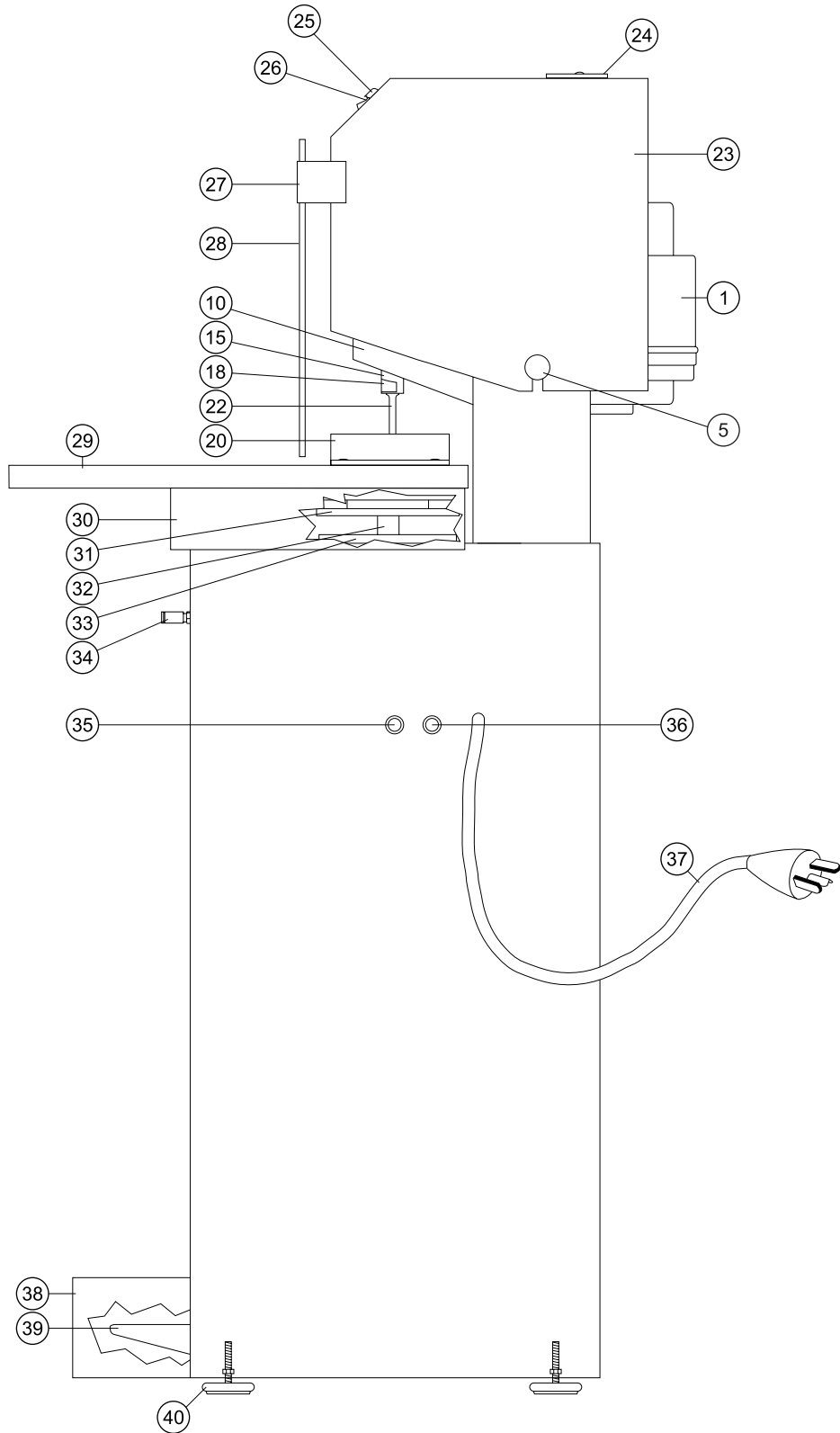

7 - Parts Diagrams

7.2 - Head Assembly

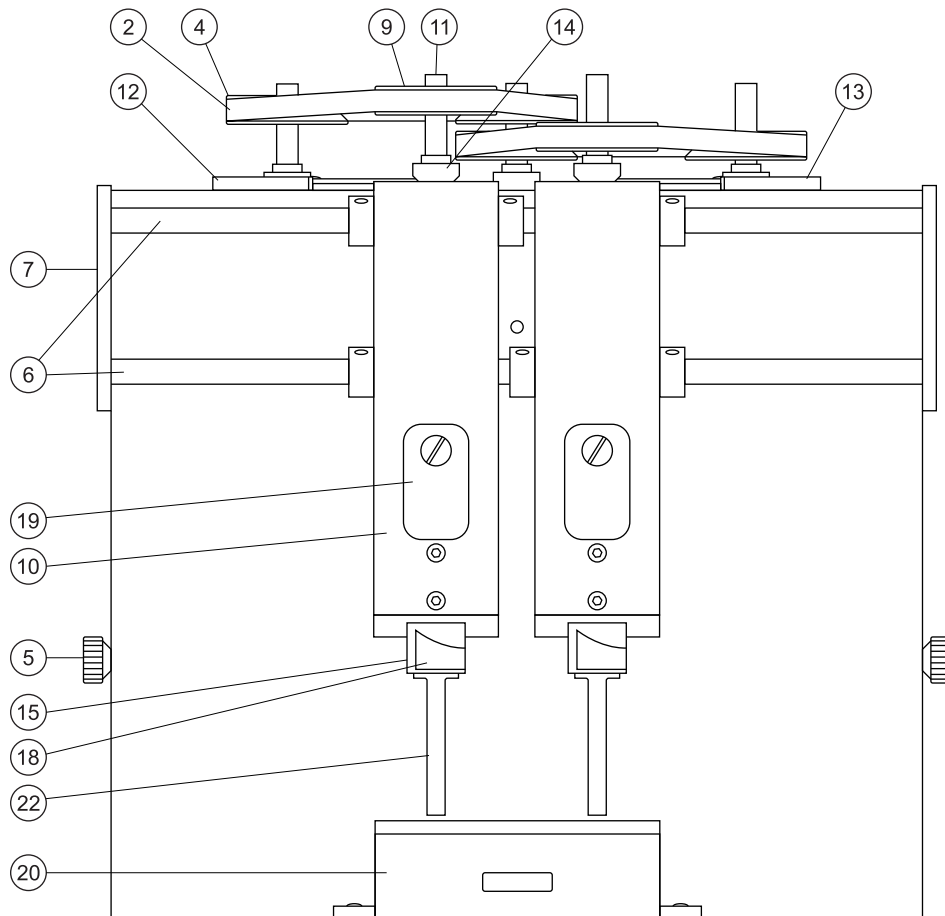
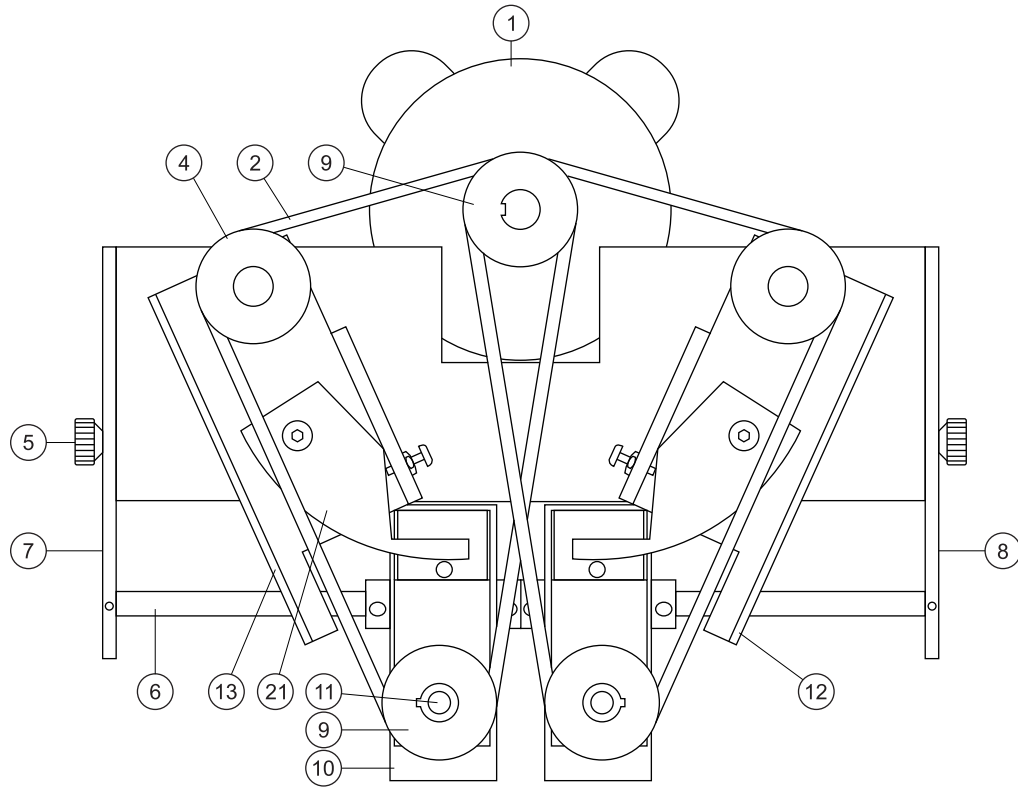

7 - Parts Diagrams

7.3 - Spindle and Chuck Assembly

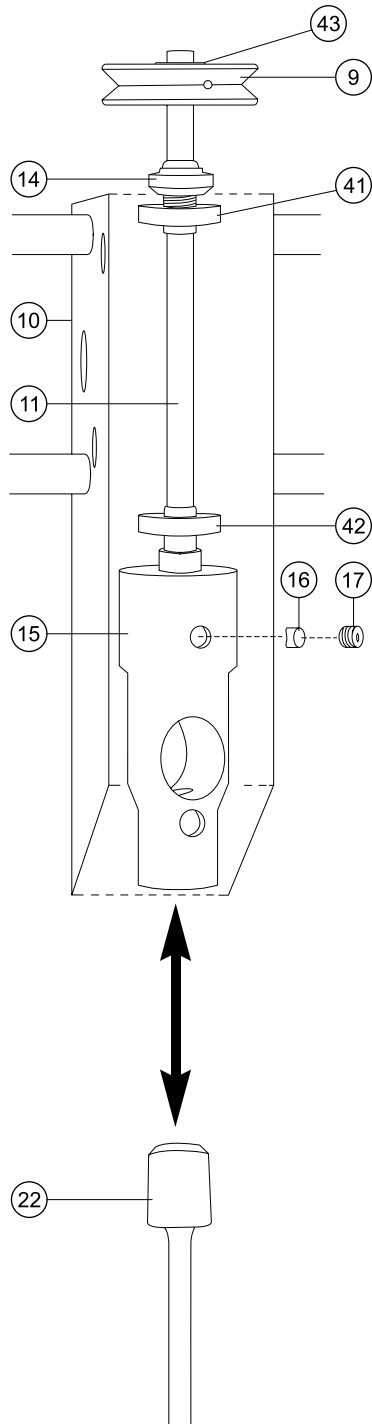

7 - Parts Diagrams

7.4 - Rear View

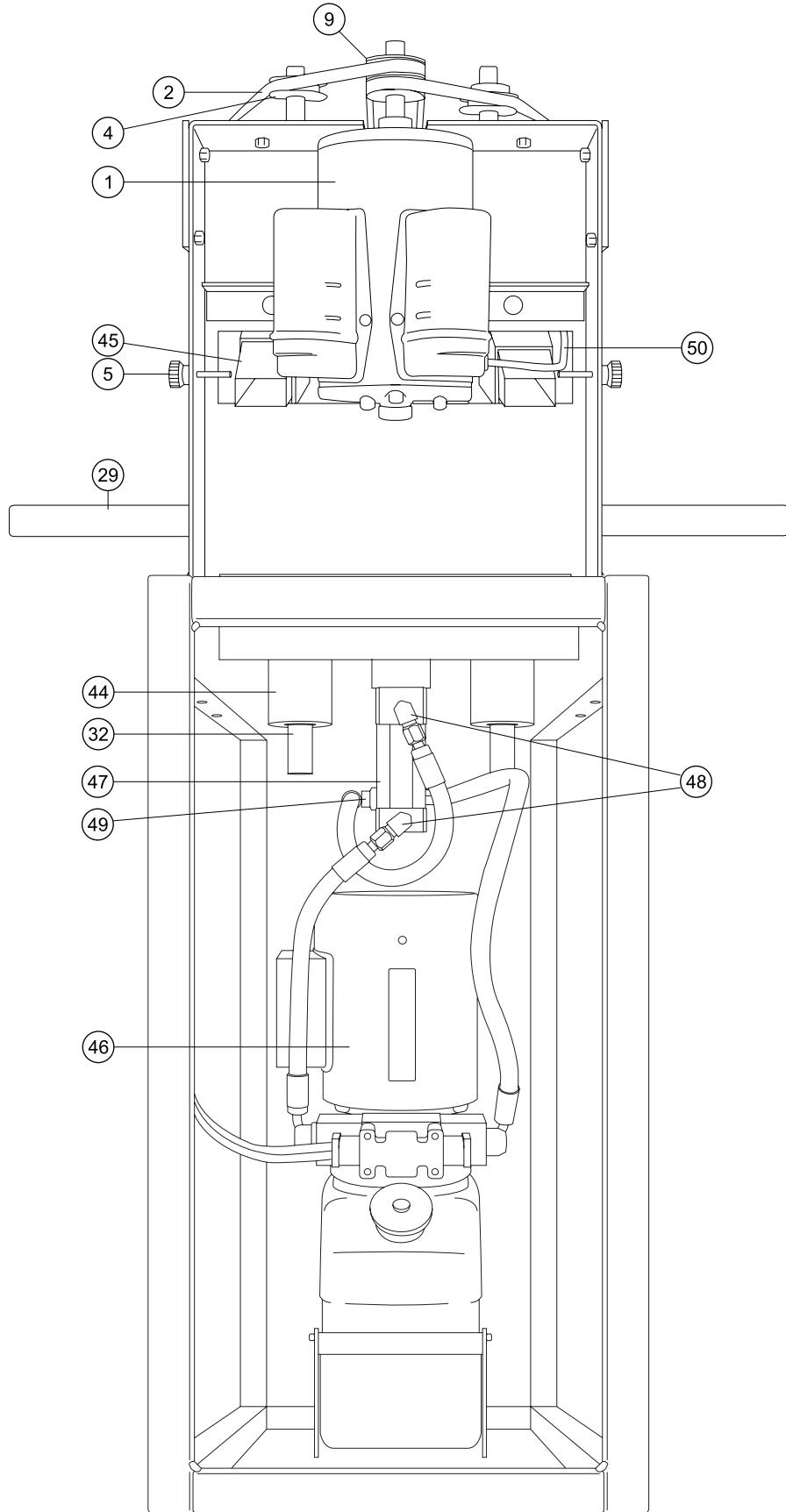

7 - Parts Diagrams

7.5 - Parts List

- ① FMM9-9534: 3/4 HP MOTOR (1)
- ② FMM9-9513: DRIVE BELT (2)
- ③ N/A
- ④ FMM9-9506: IDLER PULLEY (2)
- ⑤ FMM9-9517: SHROUD LOCKING KNOB (2)
- ⑥ FMM8-8502: TRAVERSE ROD (2)
- ⑦ FMM8-8500: END PLATE LEFT (1)
- ⑧ FMM8-8501: END PLATE RIGHT (1)
- ⑨ FMM9-9505: PULLEY (6)
- ⑩ FMM5-5506: HOUSING (2)
- ⑪ FMM5-5513: SPINDLE (2)
- ⑫ FMM9-9500: RIGHT PIVOT CHANNEL (1)
- ⑬ FMM9-9502: LEFT PIVOT CHANNEL (1)
- ⑭ FMM5-5503: BEARING NUT (2)
- ⑮ FMH-5514: CHUCK (2)
- ⑯ FMH-5515: INSERT (2)
- ⑰ FMH-5517: INSERT SCREW (2)
- ⑱ FM5-5011: CHUCK RELEASE HOLD GUARD (2)
- ⑲ FMM5-5512: ACCESS COVER (2)
- ⑳ FMH-C2A: CARD CAGE (1)
- ㉑ FMM5-5511: CAM BLOCK FOLLOWER (2)
- ㉒ 5/16" HOLLOW DRILL BIT (2)
- ㉓ FMMS9-952A: SHROUD ASMB (1)
- ㉔ FM-95: ACCESS GUARD (1)
- ㉕ FMH-1050: SWITCH GUARD (1)
- ㉖ FM5-5006: ROCKER SWITCH (2)
- ㉗ FM-90/FM-91: OUTER/INNER GUARD BRACKET (1/1)
- ㉘ FM-93: PROTECTIVE GUARD (1)
- ㉙ FMH-4000C: TABLE ASMB (1)
- ㉚ FMH-3117: SAFETY APRON (1)
- ㉛ FMH-3001C: TOP DIE SHOE (1)
- ㉜ FMH-3118: DIE PIN (2)
- ㉝ FMH-3119C: SUPPORT PLATE (1)
- ㉞ FMH-20011: NEEDLE VALVE (1)
- ㉟ FM-83: 12 AMP TIME DELAY FUSE (1)FM-82: 8 AMP TIME DELAY FUSE (1)
- ㊱ FMH-5008: CORD SET (1)
- ㊲ FMP2-2015: FOOT PEDAL GUARD (1)
- ㊳ FMH-100: FOOT PEDAL (1)
- ㊴ 50-59: ADJUSTMENT FOOT (4)
- ㊵ FMM5-5501: TOP BEARING (2)
- ㊶ FMM5-5502: BOTTOM BEARING (2)
- ㊷ FMM9-9514: PULLEY BUSHING (4)
- ㊸ FM3-3007: PIN HOUSING (2)
- ㊹ FMM6-650A: CHIP CHUTE ASMB (2)
- ㊺ FMH-2X: HYDRAULIC ASMB (1) W/HOSES (3)
- ㊻ FMH-3126: HYDRAULIC CYLINDER (1)
- ㊼ HL3H28: MALE ELBOW (2)
- ㊽ HL3H26: FITTED ELBOW (2)
- ㊾ FMM9-9535: WIRE HARNESS (1)