

Spinnit® FMM-2 Manual Paper Drill

USER'S MANUAL



Before operating this equipment, please read these instructions completely and keep these operating instructions for future reference.

Serial Number: _____
Date of Purchase: _____
Dealer: _____
Address: _____

Telephone Number: _____

Table Of Contents

1 - Introduction

- 1.1 Your New FMM-2 Paper Drill..... Page 01
- 1.2 Shipping Damage Inspection..... Page 01

2 - Safety

- 2.1 Safety Instructions..... Page 02
- 2.2 Warning Labels..... Page 03
- 2.3 Grounding Instructions..... Page 04

3 - Setting Up Your Machine

- 3.1 Loose Items Inventory..... Page 05
- 3.2 Accessories Warning..... Page 05
- 3.3 Uncrating and Removing From the Pallet..... Page 06
- 3.4 Installing the Leveling Feet..... Page 06
- 3.5 Attaching the Paper Side Stops..... Page 07
- 3.6 Attaching the Chip Bag..... Page 07
- 3.7 Electrical Instructions..... Page 07

4 - Operation

- 4.1 Protective Guard..... Page 08
- 4.2 Drill Bit Removal and Installation..... Page 08
- 4.3 Leveling the Drill Bits..... Page 09
- 4.4 Adjusting the Table Height..... Page 10
- 4.5 Adjusting the Back-Gauge Assembly... Page 10
- 4.6 Adjusting the Distance Between Holes..... Page 11
- 4.7 Adjusting the Stop Collars..... Page 11
- 4.8 Multi-hole Set-up..... Page 12
- 4.9 Traversing the Table..... Page 12
- 4.10 Drilling Procedures..... Page 13
- 4.11 Tips on Drilling..... Page 13

5 - Maintenance

- 5.1 Safety..... Page 14
- 5.2 Annual Lubrication..... Page 14
- 5.3 Inspecting the Flex Drive..... Page 16

6 - Trouble Shooting Guide

- 6.1 Determining the Cause and Correction to Certain Problems..... Page 17

7 - Parts Diagrams

- 7.1 Side View..... Page 20
- 7.2 Head Assembly..... Page 21
- 7.3 Spindle and Chuck Assembly..... Page 22
- 7.4 Rear View..... Page 23
- 7.5 Parts List..... Page 24

1 - Introduction

1.1 - Your New FMM-2 Paper Drill

- Thank you for your purchase of the Spinnit®FMM-2 Paper Drill.
- We ask that you take a moment to fill in the serial number and other information on the front cover of the manual. Please keep this manual as a reference for future use.
- For parts and service, please contact the Lassco-Wizer Dealer from whom you purchased the machine. If you require assistance in locating a Lassco-Wizer Dealer please contact our customer service department at 585-436-1934. Please have the model of your machine and the serial number when you call.

1.2 - Shipping Damage Inspection

- Remove the machine from the carton and inspect for any shipping damage. If any damage is present, report the damage to the carrier immediately; failure to do so may void any warranties.

2 - Safety

2.1 - Safety Instructions

- All operators must read and understand the Users Manual including all safety instructions before using this equipment. Failure to fully understand the safety instructions can result in personal injury. If after reading the manual you are still uncertain about use, please contact the dealer from whom you purchased the machine for assistance. If you need contact information for a Service Technician nearest you please call 585-436-1934.
- SAFETY OF THIS EQUIPMENT IS THE RESPONSIBILITY OF THE USER(S).
- Please read and follow all warning labels on your machine.
- INDUSTRIAL AND IN-PLANT USE ONLY. This equipment is for use in industrial and in-plant areas only and must be operated by trained and qualified personnel.
- WEAR PROPER APPAREL. Do not wear loose clothing, gloves, neckties, rings, bracelets, or other jewelry which may get caught in moving parts. Non slip footwear is recommended. Wear protective hair covering to contain long hair.
- Keep hands clear while operating machine.
- ALWAYS USE SAFETY GLASSES. Also use face or dust mask if drilling operation is dusty. Everyday eyeglasses only have impact resistant lenses, they are NOT safety glasses.
- KEEP GUARDS IN PLACE and in working order.
- Always disconnect the power before servicing this machine. Service should only be performed by a QUALIFIED TECHNICIAN.
- Always turn the machine to off mode and wait for the drills to stop spinning before installing or removing drill bits. Keep hands away from drills when operating. PLEASE NOTE THAT THE DRILL BITS MAY BE HOT AFTER USE. PROCEED WITH CAUTION WHEN CHANGING THE DRILL BITS.
- DON'T USE IN DANGEROUS ENVIRONMENT. Don't use this machine in damp or wet locations, or expose it to rain. Keep work area well lighted.
- THIS MACHINE IS DESIGNED FOR ONE PERSON OPERATION. Never operate the machine with more than one person.

- KEEP CHILDREN AWAY. All visitors should be kept a safe distance from the work area.
- MAKE WORKSHOP KID-PROOF with padlocks or master switches.
- DON'T FORCE MACHINE. It will do the job better and safer at the rate for which it was designed.
- USE RIGHT MACHINE. Don't force tool or attachment to do a job for which it was not designed.
- MAINTAIN MACHINE WITH CARE. Keep tools sharp and clean for best and safest performance. Follow instructions for lubricating and changing accessories.
- REMOVE ADJUSTING KEYS AND WRENCHES. Form habit of checking to see that keys and adjusting wrenches are removed from machine before turning it on.
- KEEP WORK AREA CLEAN. Cluttered areas and benches invite accidents.
- DISCONNECT MACHINE before servicing; when changing accessories, such as drill bits, drill blocks, and the like.
- REDUCE THE RISK OF UNINTENTIONAL STARTING. Make sure the power switch is in the off position before plugging in.
- USE RECOMMENDED ACCESSORIES. Consult the user's manual for recommended accessories. The use of improper accessories may cause risk of injury to persons.
- NEVER STAND ON MACHINE. Serious injury could occur if the machine is tipped.
- DON'T OVERREACH. Keep proper footing and balance at all times.
- CHECK DAMAGED PARTS. Before further use of the machine, a guard or other part that is damaged should be carefully checked to determine that it will operate properly and perform its intended function--check for alignment of moving parts, binding of moving parts, breakage of parts, mounting, and any other conditions that may affect its operation. A guard or other part that is damaged should be properly repair or replaced.
- NEVER LEAVE MACHINE RUNNING UNATTENDED. TURN POWER OFF. Don't leave machine until it comes to a complete stop.

2 - Safety

2.2 - Warning Labels

English



- WARNING: DO NOT EXPOSE TO RAIN OR USE IN DAMP LOCATIONS.

	⚠ WARNING
	Read and understand operator's manual and all other safety instructions before using this equipment

⚠ WARNING
FOR INDUSTRIAL AND IN-PLANT USE ONLY.

	⚠ WARNING
	Entanglement hazard. Rotating parts. Do NOT operate with exposed long hair, jewelry or loose clothing.

	⚠ WARNING
	Moving parts can crush and cut Keep hands clear while operating machine.

	⚠ WARNING
	Risk of eye injury. Wear eye protection.

	⚠ WARNING
	Risk of Injury. Do NOT operate without guards in place.

	⚠ DANGER	
	Severe shock hazard. Only authorized personnel may service this equipment. Turn power OFF before entry.	

French

- AVERTISSEMENT: NE PAS EXPOSER À LA PLUIE ET NE PAS UTILISER DANS LES EMPLACEMENTS HUMIDES

⚠ AVERTISSEMENT
Lire et bien comprende le manuel de l'opérateur avant d'utiliser cette machine. Le fait de ne pas suivre les consignes d'utilisation peut entraîner des blessures graves ou endommager l'équipement.

⚠ AVERTISSEMENT
POUR UTILISATION INDUSTRIELLE ET EN USINE SEULEMENT.

⚠ AVERTISSEMENT
Risque d'enchevêtrement. Pièces rotatives. Ne portez jamais de vêtements amples ou de bijoux et attachez-vous les cheveux lorsque vous opérez cette machine.

⚠ AVERTISSEMENT
Les pièces mobiles peuvent écraser et couper. Éloignez les mains lorsque vous opérez cette machine.

⚠ AVERTISSEMENT
Risque de blessures aux yeux. Protection des yeux nécessaire.

⚠ AVERTISSEMENT
Faire attention de ne pas se blesser. Ne pas utiliser cette machine sans la présence de tous les dispositifs de sécurité.

⚠ DANGER
Grave risqué d'électrocution. Seul le personnel autorisé peut faire l'entretien de cet équipement. COUPEZ l'alimentation électrique avant d'entrer.

2.3 - Grounding Instructions

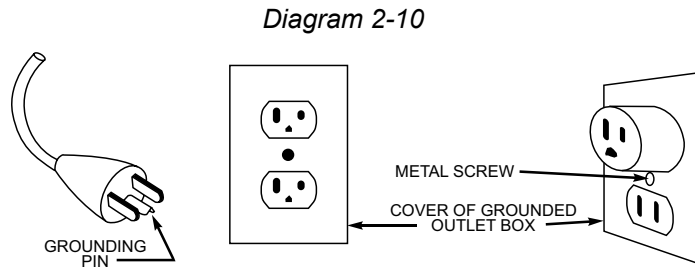

- In the event of a malfunction or breakdown, grounding provides a path of least resistance for electric current to reduce the risk of electric shock. This tool is equipped with an electric cord having an equipment-grounding conductor and a grounding plug. The plug must be plugged into a matching outlet that is properly installed and grounded in accordance with all local codes and ordinances.
- **DO NOT MODIFY THE PLUG PROVIDED.** If it will not fit the outlet, have the proper outlet installed by a **QUALIFIED ELECTRICIAN**.
- Improper connection of the equipment-grounding conductor can result in a risk of electric shock. The conductor with insulation having an outer surface that is green with or without yellow stripes is the equipment-grounding conductor. If repair or replacement of the electric cord or plug is necessary, do not connect the equipment-grounding conductor to a live terminal. Check with a **QUALIFIED ELECTRICIAN** or service personnel if the grounding instructions are not completely understood, or if in doubt as to whether the tool is properly grounded. Use only 3-wire extension cords that have 3-prong grounding plugs and 3-pole receptacles that accept the machine's plug.
- This machine is intended for use on a circuit that has an outlet that looks like the one illustrated in diagram 2-10. The machine has a grounding plug that looks like the plug illustrated in diagram 2-10. Make sure the machine is connected to an outlet having the same configuration as the plug. No adapter is available or should be used with this machine. If the machine must be reconnected for use on a different type of electric circuit, the reconnection should be made by qualified service personnel; and after reconnection, the tool should comply with all local codes and ordinances.

3 - Setting Up Your Machine

3.1 - Loose Items Inventory

- Please remove and inspect the following items:

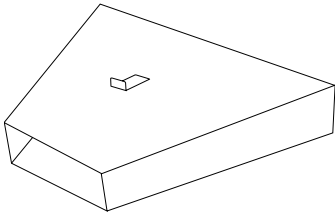

FMM6-651A: Master Chip Chute (1)
(This item may be installed)

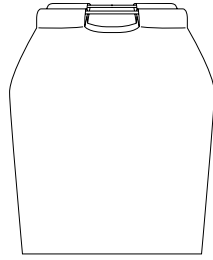

FMM6-652A: Chip Bag Assembly (1)

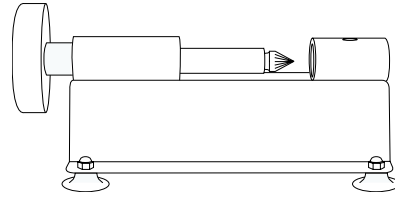

MS-1: Drill Sharpener (1)

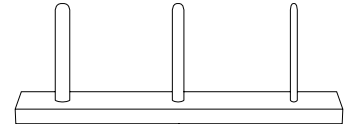

CC-2: Chip Clearer (1)

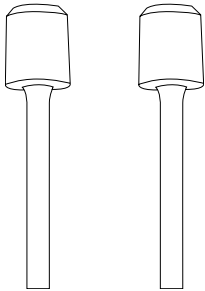

Hollow Drill Bits (2)
(these items may be installed)

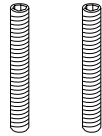

Short Set Screws (2)

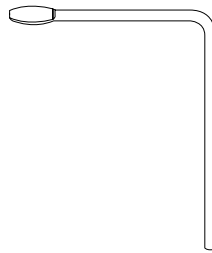

EBM-32: Chuck Release Key (1)

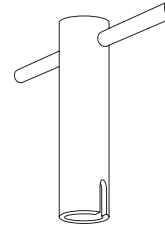

FMM9-957A: Spindle Rotation Tool (1)



EBM-41: Sharpening Stone (1)

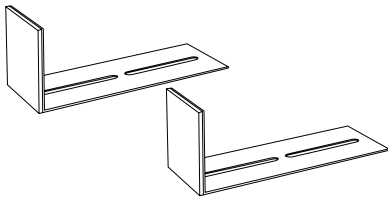

Paper Side Stops (2)

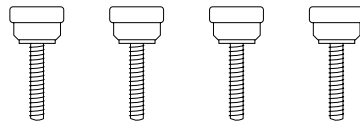

FM4-4007: Side Stop Screws (4)



HEX-332: Hex Wrench 3/32" (1)

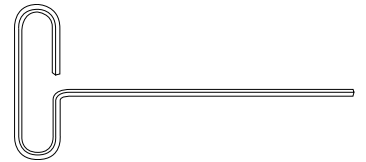

HEX-732-T: Hex Wrench 7/32" T Style (1)



DRILL-EASE: Drill Bit Lubricant (1)



FM4-4001: 25" Drill Strip (1)
(this item comes installed)

3.2 - Accessories Warning

- **USE RECOMMENDED ACCESSORIES.** Only use accessories approved by a Lassco-Wizer. The use of improper accessories may cause risk of injury to persons.

3 - Setting Up Your Machine

3.3 - Uncrating and Removing From the Pallet

- 3.3.1** Remove the wooden framing around the outside box.
- 3.3.2** Remove the box up and over the machine.
- 3.3.3** Remove the two (2) 5/16" bolts which are securing the machine to the pallet: access through the rear of the machine using a 5/16" wrench (not provided) as shown in diagram 3-10. Discard the two (2) 5/16" bolts.
- 3.3.4** Remove the FMM-2 from the pallet carefully "stepping" it off the edge. **DO NOT** drop the machine. **DO NOT** lift by the table. Two people may be needed to remove the machine from the pallet safely.

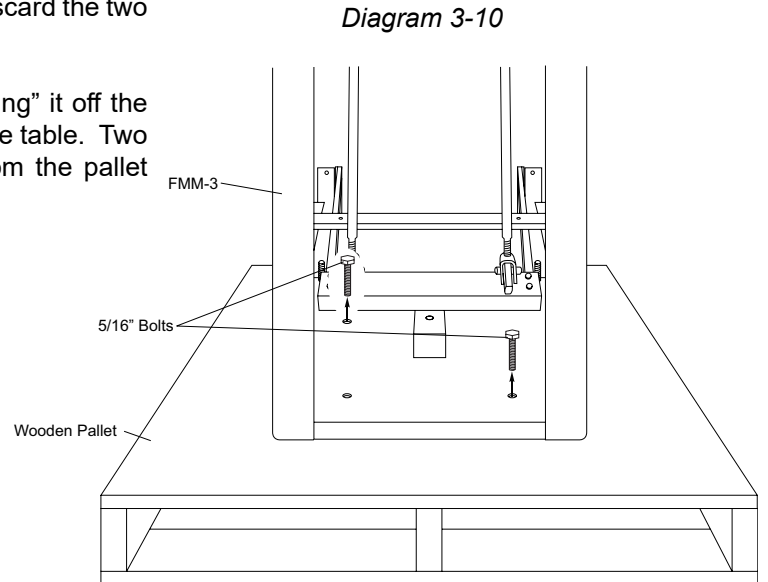

3.4 - Installing the Leveling Feet

- 3.4.1** Set the machine down in its desired location and determine if the machine is level, making sure that it does NOT rock in any direction. If it does, determine which Leveling Feet need to be adjusted and whether they need to be adjusted up or down.
- 3.4.2** If adjustment is needed, start by loosening the four (4) nuts which are accessed through the rear of the machine.
- 3.4.3** Next adjust the four (4) Leveling Feet by screwing them clockwise to raise the or counter-clockwise to lower. After each adjustment set the machine down completely to verify that the machine no longer rocks. Continue adjustment as needed until the machine sits securely in place. Tighten the four (4) nuts down to secure the position of the Leveling Feet.

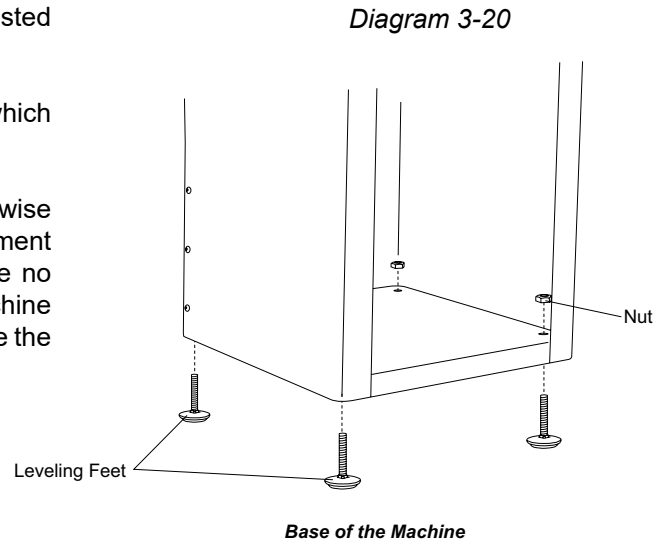

3 - Setting Up Your Machine

3.5 - Attaching the Paper Side Stops

- 3.5.1** Attach the Paper Side Stops using two (2) Side Stop Screws (FM4-4007) each. Position the Paper Side Stop as desired and tighten down with light pressure.

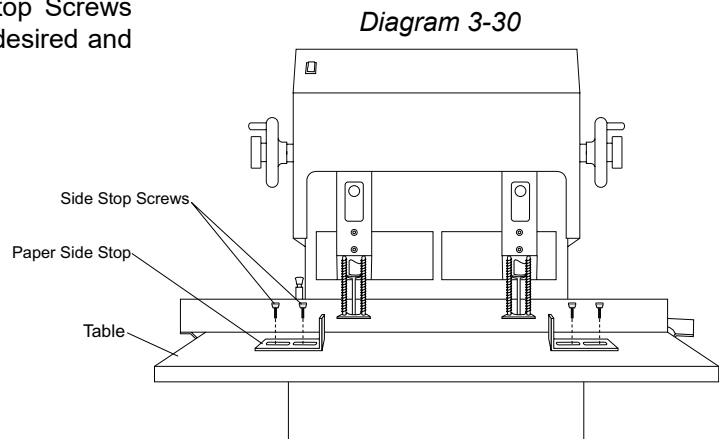

3.6 - Attaching the Chip Bag

- 3.6.1** Attach the Chip Bag (FMM6-652A) to the machine by stretching the mouth of the bag over the Master Chip Chute and hooking the aluminum bar onto the bracket located on the top flat portion of the master chip chute as shown. Please note that you must empty this bag as needed to avoid clogging.

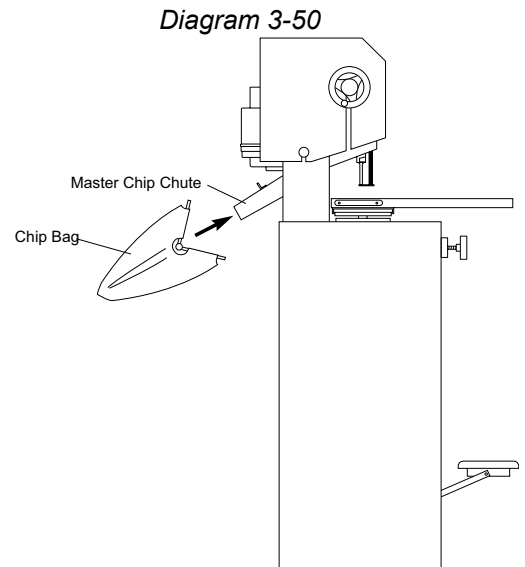

3.7 - Electrical Instructions

- 3.7.1** Your FMM-2 comes with an electrical cord containing the plug to fit into a standard grounded 115V outlet. This machine has a full load draw of 11 Amps.

- 3.7.2** Making sure that nothing is interfering with the drill bits, plug the cord set into a grounded 115V outlet. To turn the machine on, press the Rocker Switch on the front of the shroud.

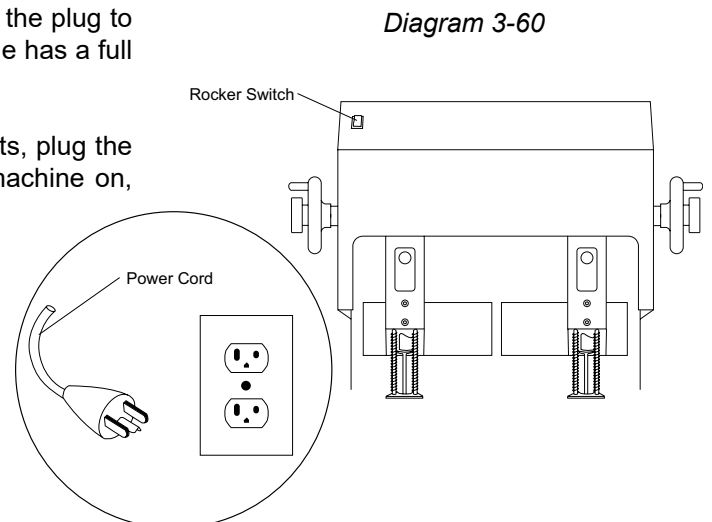

4 - Operation

4.1 - Protective Guard

- 4.1.1** Your FMM-2 comes with a protective guard installed. DO NOT operate this machine without the guard in place.
- 4.1.2** Please note that when you are performing certain operations such as removing and installing drill bits, you will need to move the guard out of the way. Making sure the power to the machine is disconnected or locked-out, push the guard up and hold in place while performing necessary operations or maintenance. The protective guard should not be removed during operation.

Diagram 4-10

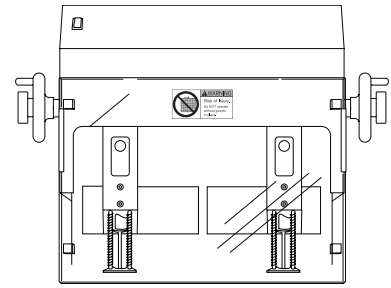

4.2 - Drill Bit Removal and Installation



CAUTION: DRILL BITS MAY BE HOT AFTER USE. ALLOW DRILL BITS TO COOL DOWN BEFORE TOUCHING.



BEFORE REMOVING OR INSTALLING THE DRILL BITS, DISCONNECT OR LOCK-OUT THE POWER SUPPLY.

- 4.2.1** Remove the hole guard which is attached to the chuck. This is done by grasping the tab and sliding the guard off.
- 4.2.2** Using the Chuck Release Key (EBM-32), insert the tapered end facing down into the chuck hole. With a clockwise motion turn the Chuck Release Key 45 degrees. The drill bit will slide out of the spindle. It is recommended that you hold onto the drill bit so that it does not drop out of the spindle damaging the tip. Place the hole guard back onto the chuck to protect debris from clogging the spindle.

Diagram 4-20

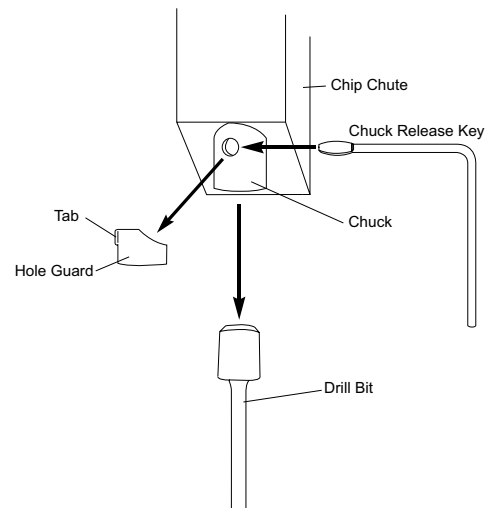

- 4.2.3** To install a drill bit, grasp the drill bit and being careful to keep it straight, press it up into the Chuck.
- 4.2.4** Seat the drill bit by using a stack of scrap paper. Set the scrap on the table as shown. Step on the foot pedal slowly raising the table toward the drill bit. Put light pressure on the hollow drill bit seating it firmly in place.
- 4.2.5** Remove the scrap paper and turn the machine on to check the concentricity of the bit. If the bit is not concentric, remove it and repeat steps 4.2.1 through 4.2.4 until it is concentric.

Diagram 4-30

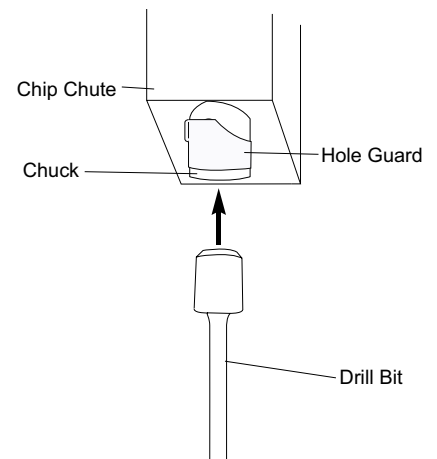

4 - Operation

4.3 - Leveling the Drill Bits

- 4.3.1** We recommend using a piece of card stock on the Table when leveling the drill bits to avoid drilling into the drill strip. This will lengthen the life of your drill bits and keep them sharper.
- 4.3.2** Remove one (1) of the two (2) Access Guard Screws using the 1/8" Hex Wrench (HEX-18). Swing the Access Guard as shown in diagram 4-40 to gain access to the motor shaft.
- 4.3.3** Insert the Spindle Rotation Tool (FMM9-957A) into the end of the motor shaft through the opening in the top of the machine shroud until the notch in the Spindle Rotation Tool fits into the keyway securely.
- 4.3.4** Swing the access cover located on the front of the heads to one side allowing access to the spindle and chuck.
- 4.3.5** Turn the Spindle Rotation Tool by hand until the insert retainer screw can be seen in the opening.
- 4.3.6** Stepping slowly on the foot pedal, raise the table so that it meets the bottom of the pressure foot assembly.
- 4.3.7** Using the 7/32" Hex Wrench (HEX-732-T), loosen the insert retainer screw approximately one half turn (loosening too much may cause the insert retainer screw to come out completely). Retighten the insert retainer screw until it is snug but not tight; this will allow you to raise or lower the chuck without too much play. Hold onto the Spindle Rotation Tool to prevent the belts from turning. Lower the height of the Chuck by turning it counter-clockwise. Raise the height of the Chuck by turning it clockwise.
- 4.3.8** When the drill bit is just touching the drill strip, re-tighten the insert retainer screw. This may require you to turn the Spindle Rotation Tool until the Insert Retainer Screw is again accessible through the opening.
- 4.3.9** Lower the table by slowly releasing pressure on the foot pedal.
- 4.3.10** Repeat steps 4.3.4 through 4.3.9 on the remaining Drill Bits so that they are all level with each other.
- 4.3.11** REMOVE THE SPINDLE ROTATION TOOL FROM THE MOTOR SHAFT. Leaving this attached can cause injury to the user as it can fly out of the machine upon startup.
- 4.3.12** Replace all the Access covers and Access Guards so that they cover the motor shaft opening and the retainer screw openings.

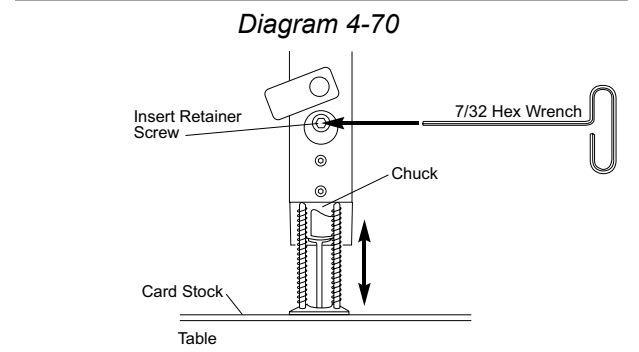
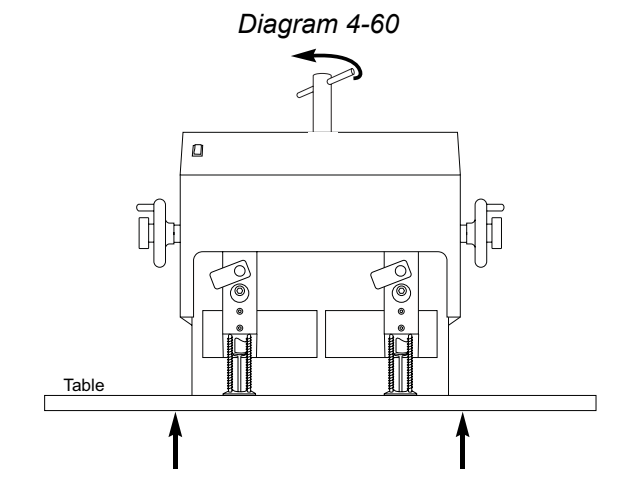
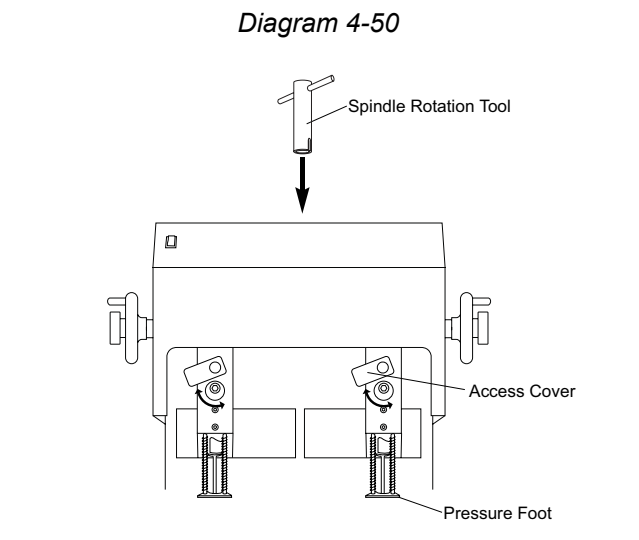
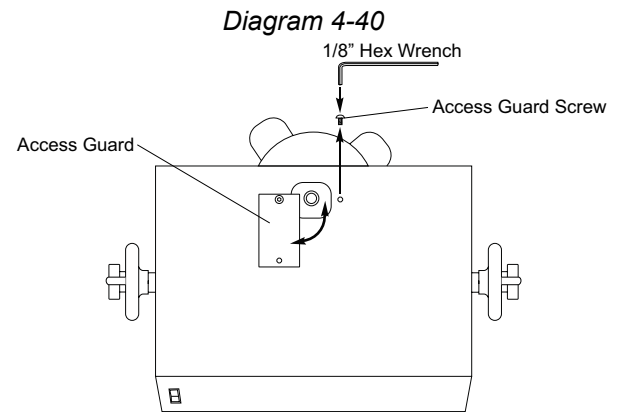

4 - Operation

4.4 - Adjusting the Table Height

4.4.1 After you level the drill bits you may need to adjust your table height. Test drill through a stack of scrap approximately the same height as that you will be drilling. If the drill bits drill into the Drill Strip or if the drill bits fail to penetrate through the bottom sheet of scrap you will need to adjust the table height. If you are using the card stock under your scrap (recommended) then you should just be lightly scoring the card stock when the table is in its full upright position. If your bits are drilling correctly move onto section 4.4.

4.4.2 If your drill bits fail to penetrate through the scrap: Loosen the Lock Knob of the Vertical Stop Adjustment Assembly and rotate the large knob counterclockwise allowing the table to travel higher. Tighten down the Lock Knob when it is positioned correctly.

4.4.3 If you are drilling into the Drill Strip: Loosen the Lock Knob of the Vertical Stop Adjustment Assembly and rotate the large knob clockwise allowing the table to travel lower. Tighten down the Lock Knob when it is positioned correctly.

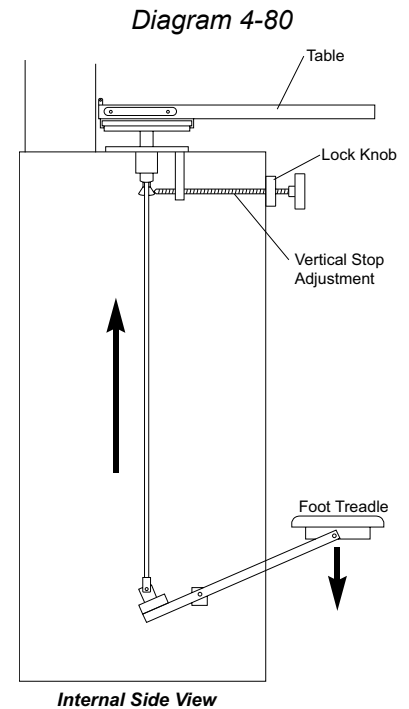

4.5 - Adjusting the Back-Gauge Assembly

4.5.1 Adjust the Back-gauge so that it is the correct distance from the edge of the product to the center of the hole to be drilled by performing the following:

4.5.2 Loosen the Clamp Knob on the right side of the Back-gauge.

4.5.3 Using the two (2) Scales embedded in the rear corners of the table, align the front edge of the Back-gauge with the desired distance.

4.5.4 Zero (0) on these scales align with the center of the hollow drill bits.

4.5.5 Tighten down the Clamp Knob when the Back-gauge is positioned as desired.

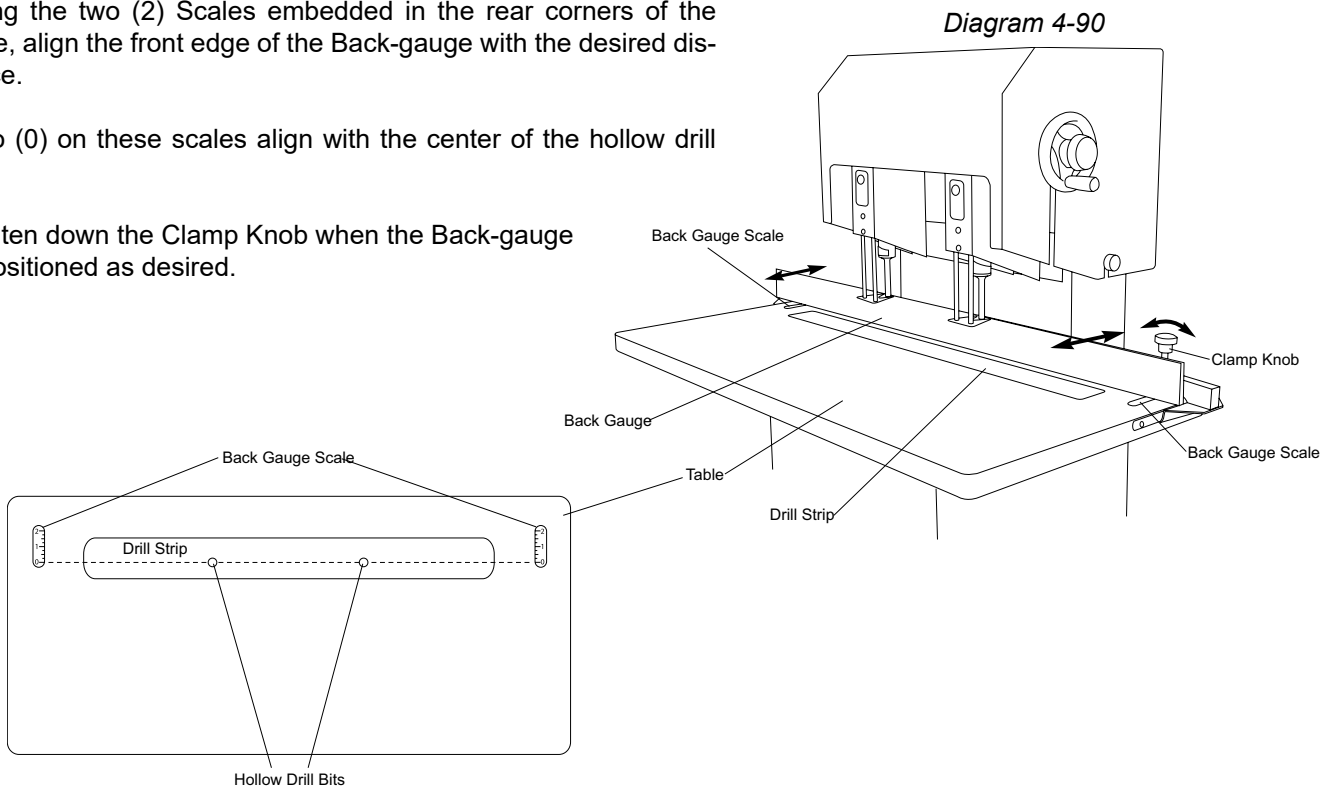

4 - Operation

4.6 - Adjusting the Distance Between Heads

4.6.1 To adjust the spindles to a desired spacing, loosen the Hand Wheel Lock Knob. Turn the Hand Wheel to move the spindle farther away from the center or to move the spindle closer to the center. Please note that the direction you turn the Hand Wheel depends on the side of the machine. Use the Back-gauge Scale as a guide. When the spindle is at its desired location tighten the Hand Wheel Lock Knob by turning clockwise. Repeat with the second spindle.

4.6.2 When drilling fewer than two (2) holes simply remove undesired drill bits.

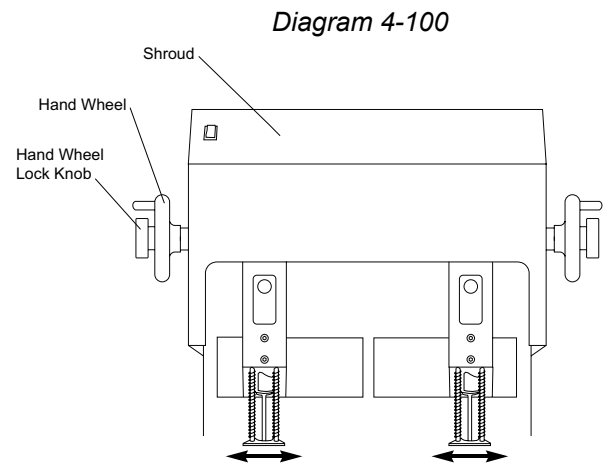

4.7 - Adjusting the Stop Collars

4.7.1 The stop collars, located on the Stop Rod at the left rear of the Table, are used to either create a stationary table mode of operation or a traversing mode. Your machine comes set up in stationary mode.

4.7.2 For traversing table operations follow steps 4.7.3 through 4.7.5. Refer to diagram 4-110.

4.7.3 Install the shorter Set Screws included with the machine into the Stop Collars. Make sure all the Stop Collars are installed with the shorter Set Screws keeping them loose enough to allow the Stop Collars to slide into the desired positions.

4.7.4 Set the Stop Collars using the method explained in section 4.8.

4.7.5 When the Collars are positioned as desired, tighten down the short Set Screws locking them in place using the provided Hex Wrench (HEX-332).

4.7.6 For stationary table operations follow steps 4.7.7 through 4.7.9. Refer to diagram 4-120.

4.7.7 Align the table so that zero (0) on the Back-gauge is aligned with the center drill bit.

4.7.8 Install two longer Set Screws included with the machine into the adjacent Stop Collars.

4.7.9 Tighten, with the provided Hex Wrench (HEX-332), the longer Set Screws into the Stop Collars so that a Set Screw rests against each side of the Pedestal preventing movement of the Table.

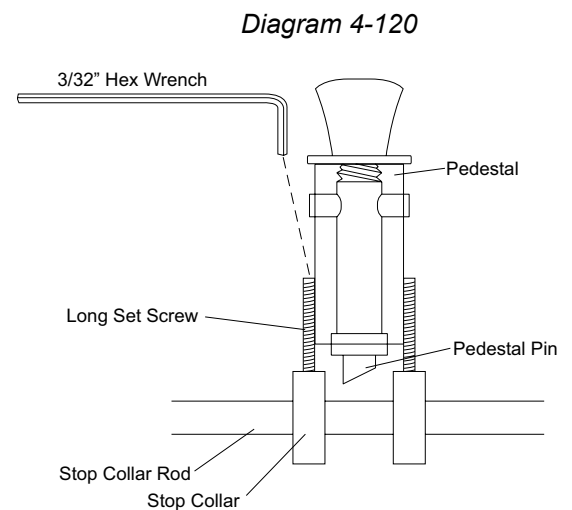
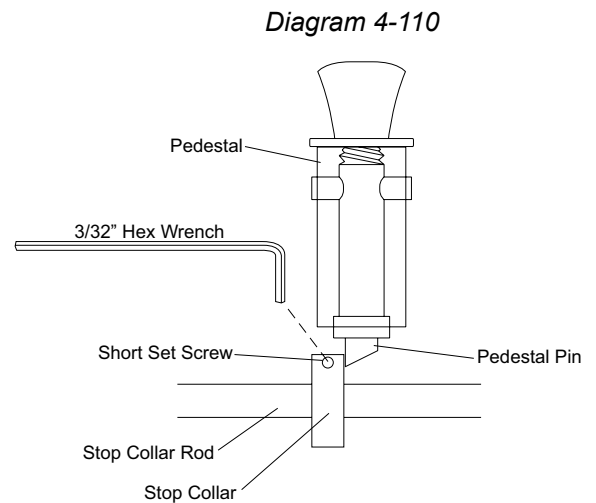

4 - Operation

4.8 - Multi-hole Set-Up

- 4.8.1** If a hole pattern includes more than three (3) holes, you will need to adjust the Stop Collars to the desired spacing. The Stop Collars are adjusted as described in section 4.7. To set the distance between the stop collars, follow steps 4.8.2 through 4.8.5.
- 4.8.2** Locate the product on the Table and adjust the Paper Side Stops to trap the material allowing no lateral movement.
- 4.8.3** Move the Table to align zero (0) on the Back-gauge Scale with the center drill bit.
- 4.8.4** Loosen the Stop Collars and position the first one against the Pedestal Pin marking the beginning position of the Table and tighten in place.
- 4.8.5** The right side of this Stop Collar now indicates the center of the product to be drilled. Place the remaining Stop Collars as desired by measuring with a Ruler (not provided) to the desired positions and tighten them down. Always measure from the right side of the Stop Collar to the right side of the next Stop Collar as shown.

Diagram 4-130

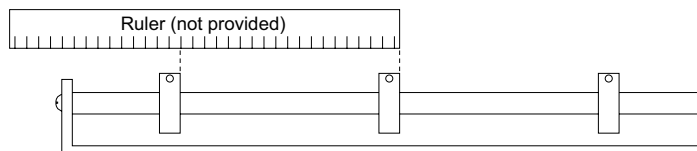

- 4.8.6** Due to the width of the Stop Collars, the shortest travel between holes is 3/8". Almost any center-to-center distance can be drilled, but requires variations of table travel and lateral head adjustments.

4.9 - Traversing the Table

- 4.9.1** When all the Stop Collars are positioned as desired return the Table to its original position. When traversing the Table during drilling (see section 4.10), move the Table to the left until the Pedestal Pin "clicks" over the next Stop Collar. Pull the table back to the right and hold it there to assure contact between the Stop Collar and the Pedestal Pin. Refer to diagram 4-140. Continue drilling and repeat as needed.
- 4.9.2** To reverse the direction of the Table traverse, lift up on the Pedestal Pin Knob and turn it around. This will cause the angle of the Pedestal Pin to reverse allowing the Table to travel back over the Stop Collars. There are Locking Pins on the Pedestal Pin that fit into a groove on the Pedestal keeping it locked into a direction. Refer to diagram 4-150.

Diagram 4-140

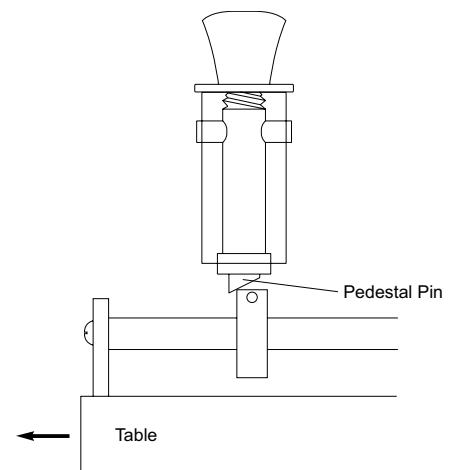
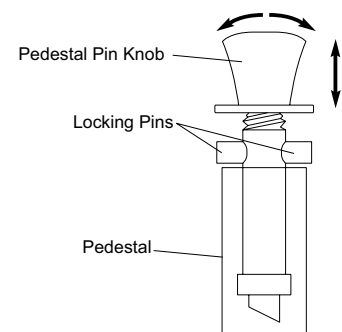

Diagram 4-150



4 - Operation

4.10 - Drilling Procedures

4.10.1 After all your adjustments are made as desired, position the Table in its original position. Set the product to be drilled on the table and make sure it is secure using the Paper Side Stops. To drill, step down on the Foot Treadle raising the Table up to meet the drill bits. Using one consistent smooth stroke, put pressure on the Treadle so that the Table rises fully allowing the drill bits to drill through the product. It is important you maintain a consistent speed through the entire stack. It is also important you do not go too slow or too fast. If you drill too slow you can burn the paper leaving undesired marks. If you drill too fast, the drill bits will act more like a punch and they will break.

4.10.2 Different product requires different speeds. It is always recommended to drill through a test stack of the product until the operator is confident of the required speed.

Diagram 4-160

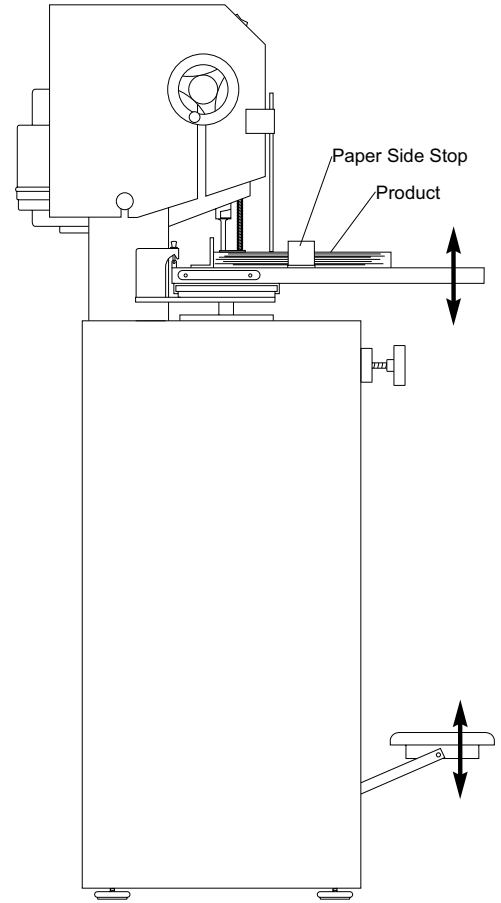

4.11 - Tips on Drilling

- 4.11.1** Use a sharp drill bit at all times... Using the MS-1 drill bit sharpener, sharpen your drill bits regularly. Apply light pressure when sharpening. Too much pressure may cause flaring of the tip. (Once a drill bit has a flared tip, it becomes defective.)
- 4.11.2** Sharpening Stone... Use to debur the outside cutting edge of the drill bits for better performance.
- 4.11.3** Lubricate drill bits occasionally... Use Drill-Ease or Spin-Eze. While the drill is running, simply touch the Drill-Ease stick to the drill bit or brush on the Spin-Eze. Drill through scrap to remove any excess. This will allow for a smoother cut.
- 4.11.4** Drill Strips...When drilling, a drill bit must stop slightly above the drill strip. Replace worn out drill strips regularly to ensure proper drilling.

5 - Maintenance

5.1 - Safety



ALWAYS DISCONNECT THE POWER BEFORE PERFORMING MAINTENANCE ON THIS MACHINE. MAINTENANCE SHOULD ONLY BE PERFORMED BY A QUALIFIED TECHNICIAN.



KEEP HANDS CLEAR WHILE PERFORMING MAINTENANCE ON THIS MACHINE. MOVING PARTS CAN CRUSH AND CUT.

5.2 - Annual Lubrication

5.2.1 Lubricating your FMM-2 should be done at least once every 12 months; however, it may be necessary to lubricate certain parts more often depending on use. Whenever a moveable or adjustable part starts becoming difficult to move or adjust, it may be time to lubricate.

5.2.2 Remove the Table by loosening the left end Stop Collar on the Stop Bar Assembly and rotating the Table Traverse Stop down to clear the Pedestal. Pull the Table to the right until the Table clears the slide beneath the Table. Inspect the slide for build-up and lubricate with light machine oil. Using the Foot Treadle raise the Slide and Lubricate the bars underneath the Slide as shown. Replace the Table in the same manner as it was removed and check the Table traverse for free travel. Refer to diagram 5-10.

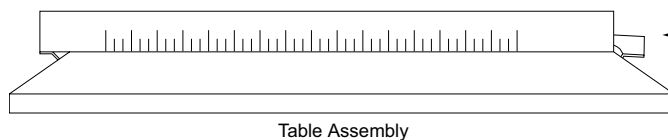

Table Assembly

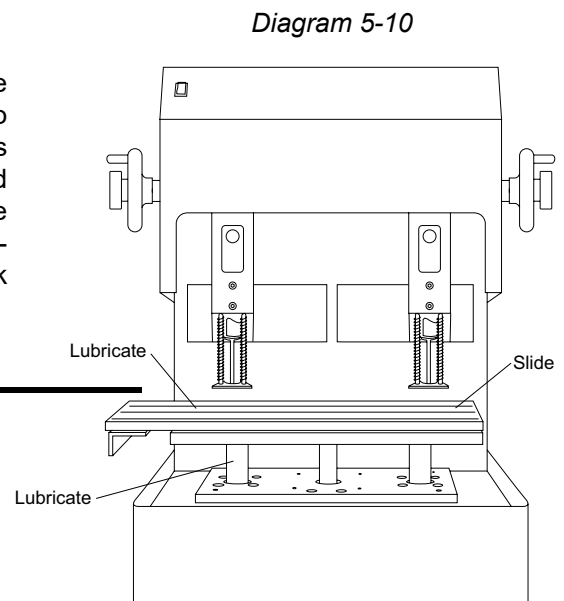

Diagram 5-10

5.2.3 Lubricate the Stop Pin with light machine oil, work the pin up and down and rotate it a few times for proper lubrication. Refer to diagram 5-20.

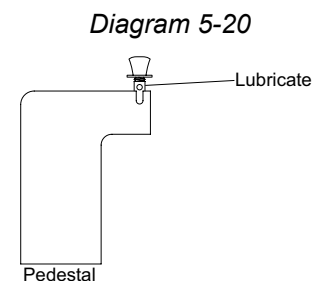

Diagram 5-20

5.2.4 Lubricate the pivot points, shown in the diagram 5-30, in the lower back portion of the machine with light machine oil. Lubricate the Treadle Pivot Assembly at the front of the machine in the same manner.

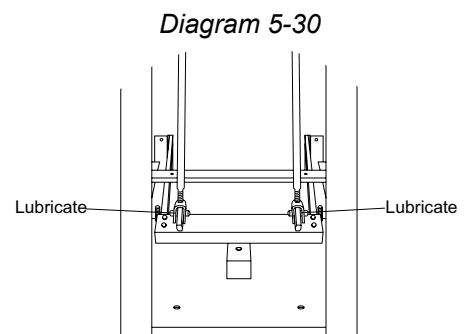
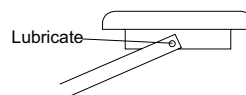

Diagram 5-30

5 - Maintenance

5.2 - Annual Lubrication

5.2.5 Press down on the Foot Treadle to Raise the Table. Manually holding the Table in place, slowly let up on the Foot Treadle so that the Push Rods in the rear of the machine fall out of the Pin Housings.

5.2.6 Lubricate the tips of the Push Rods and while holding up the Table return the Push Rods into the Pin Housings. Release the Table so that the Push Rods are locked in place.

5.2.7 Push down on the Foot Treadle to check for freedom of Travel.

5.2.8 Making sure the machine is unplugged and after disconnecting the electrical wiring to the Switch on the shroud, remove the shroud by lifting straight up to clear the drive mechanism making sure the Traverse Locks are disengaged.

5.2.9 Lubricate the Head Traverse Screws by applying light grease either by hand, or a small brush to the points indicated in diagram 5-60. Move the heads to both extremes to coat the complete surface of the screws and inspect them for thread wear.

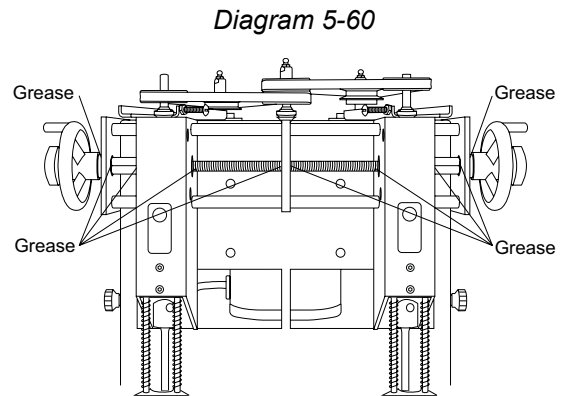
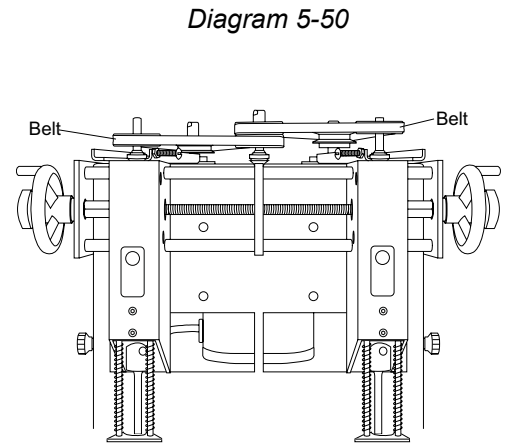
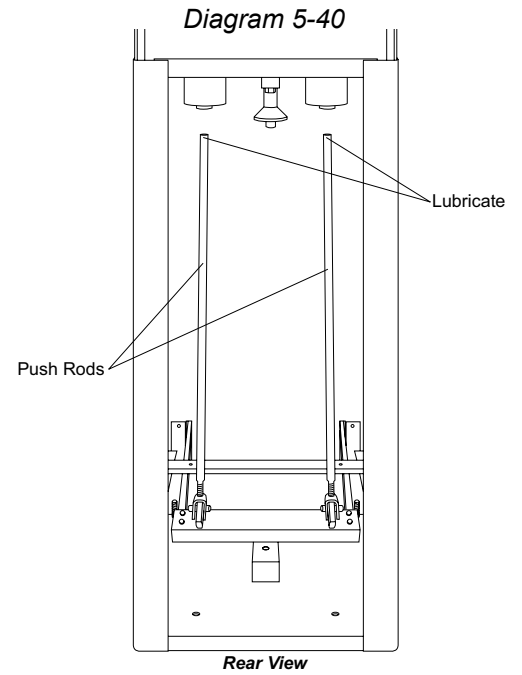

5 - Maintenance

5.2 - Annual Lubrication

5.2.10 Apply a light grease on the two (2) Traverse Rods either by hand or with a small brush to the points indicated in diagram 5-70. Crank both heads in and out to distribute the lubrication and to check the head movement.

Diagram 5-70

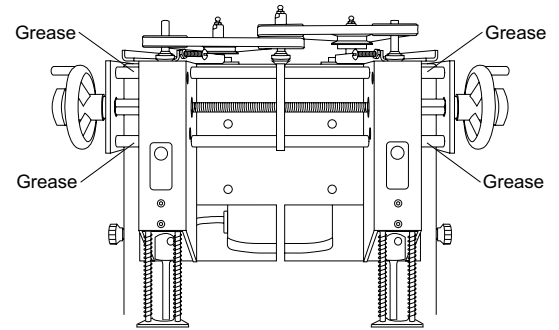

5.3 - Inspecting the Flex Drive

5.3.1 Inspecting the Flex Drive on your FMM-2 should be done at least once every 12 months; however, it may be necessary to check this more often if problems with the rotation of the spindles is noticed. Pelt shavings are normal for new adjusted belts, but contact a service technician if it becomes excessive.

5.3.2 Inspect the Belts for wear and the proper tension. The tension should be adjusted to an approximate 1/2" gap between a straight edge placed from the outside edge of the Idler Pulley to the outside edge of the Outside Pulley with the pulleys located one behind the other. Depress the belt halfway between the two pulleys and measure the distance between the straight edge and the belt depression.

Diagram 5-80

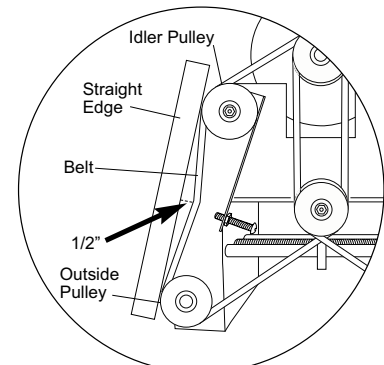

Belt Tension

5.3.3 The belts can be adjusted by loosening the Lock Nut on the Belt Adjustment Screw located on the front portion of the Flex Drive Pivot Assembly and turning the screw clockwise to tighten the belt and counterclockwise to loosen the belt. After the belt has been properly adjusted, re-tighten the Lock Nut.

Diagram 5-90

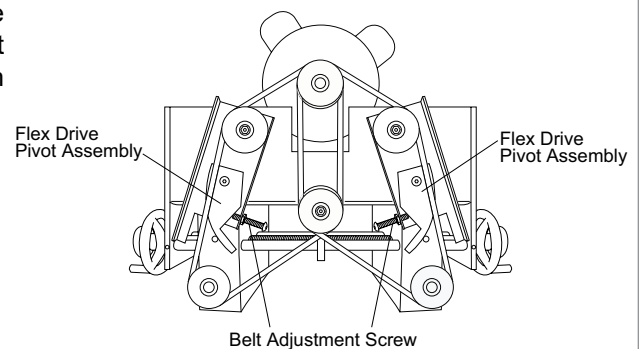

5.3.4 Visually check the Flex Drive Pivot Assembly for unusual wear. Check the Pivot Assembly bolts and tighten if necessary.

Diagram 5-100

5.3.5 Be sure the wiring is clear of all moving components and is properly attached when replacing the Shroud.

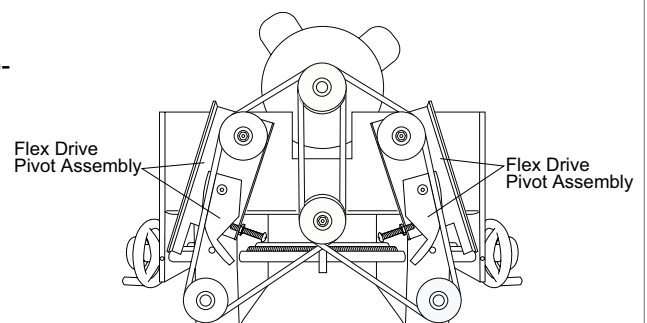

6 - Trouble Shooting Guide

6.1 - Determining the Cause and Correction to Certain Problems

Problem	Cause	Correction
Drill bit not concentric.	Foreign material in chuck or in drill plug.	Inspect and clean.
	Drill bit is bent.	Replace drill bit.
	Drill bit not seated in chuck properly.	Re-insert drill bit correctly. (See <i>Operating Instructions</i>)
	Chuck is not tight to spindle.	Tighten set screw.
Drill bit not drilling.	Drill bit plugged.	Remove and clear chips. Check for other foreign matter.
	Drill bit dull.	Sharpen drill bit.
	Note: In extreme conditions, the drill chuck and/or chip chute may be plugged. Remove the drill bit, loosen the chip chute, pull down, and clean. See <i>Operating Instructions</i>	
Traverse table drags or skips during operation.	Spring Plungers on the Slide Plate are out of adjustment or damaged.	Adjust or replace the Spring Plungers.
	Table traverse channel and/or slide is dirty or needs lubrication.	Clean the channel and lubricate.
	The Table is damaged.	Repair or replace the Table.
	Note: In order to maintain smooth table operation, DO NOT sit on, lean on, or force the table out of alignment.	
Table lift system lifts unevenly or is noisy.	Loose or missing pivot components in the Treadle Pivot Assembly.	Tighten or replace as necessary.
	Push Rods out of adjustment.	Adjust Push Rods to lift evenly.
	Bushings in the lift system are dry or worn.	Lubricate or replace.
	Push Rods are bent.	Replace
	Note: If the raising mechanism is lifted without depressing the Foot Treadle, the Push Rods will drop out of position and must be re-installed in the Pushpins in order to operate the Table.	

6 - Trouble Shooting Guide

6.1 - Determining the Cause and Correction to Certain Problems

Problem	Cause	Correction
Machine vibrates, wobbles, resonates, etc.	The machine is not level on the floor.	Use the leveling feet to make the machine level on the floor. See <i>Setting Up Your Machine</i> .
	The machine is located directly on a concrete floor.	Place a rubber mat or carpet under the machine.
	Drill bit(s) are not concentric.	Re-install drill bit(s) until they are concentric. See <i>Operating Instructions</i> .
The drill bit(s) are drilling into the drill strip or they are not drilling through the bottom sheet of the product you are drilling.	Drill bit(s) are not adjusted properly to the card stock/card stock not used.	Adjust your drill bit(s) per <i>Operating Instructions</i> .
	The Chuck(s) were not tightened after adjustment.	Re-adjust and tighten.
	The Table Travel Stop is out of adjustment.	Adjust to the proper Table Travel. See <i>Operating Instructions</i> .
The outside Heads are difficult to adjust.	The Lead Screw and/or Traverse Rods are dry or damaged.	Lubricate per <i>Maintenance</i> schedule. Check for damaged or worn components.
	The Hand Wheel Lock is tightend down in place.	Loosen the Hand Wheel Lock enough so the Hand Wheel can be turned.
	An obstruction is between the traversing heads.	Check and remove the obstruction.
The drill bit(s) do not rotate when the motor is turned on.	A Drive Belt is broken on the Flexible Drive System.	Replace the broken belt. See <i>Maintenance</i> .
	A Drive Belt is loose on the Flexible Drive System.	Tighten the loose belt. See <i>Maintenance</i> .
	An Insert Retainer Screw is hitting the inside of the Chuck Housing.	Adjust the Chuck and tighten the Insert Retainer Screw.

6 - Trouble Shooting Guide

6.1 - Determining the Cause and Correction to Certain Problems

Problem	Cause	Correction
Uncommon metallic sounds from under the shroud.	The Drive Pulley is loose.	Adjust the Drive Pulley to the proper height and tighten or replace the Set Screw.
	The Needle Bearings on the Idler Pulley(s) are not lubricated.	Lubricate the Needle Bearings as needed.
The Chuck cannot be adjusted according to the <i>Operating Instructions</i> .	The Chuck has been adjusted too far down causing the adjustment threads to be disengaged.	Re-adjust to a lower position which may require you to use new hollow drill bits.
	The Chuck has been rotated while in the down position.	Push up on the Chuck and rotate slowly while holding the Spindle stationary until the Chuck returns into a locked position.
	Note: The Chuck adjustment is designed for a 1/4" total movement up and down. Once you have sharpened the drill bit down more than a 1/4" from its original length you must replace it. Any drill bits that are longer than approx 2-1/4" or shorter than approx 2" may cause Chuck adjustment problems.	

7 - Parts Diagrams

7.1 - Side View

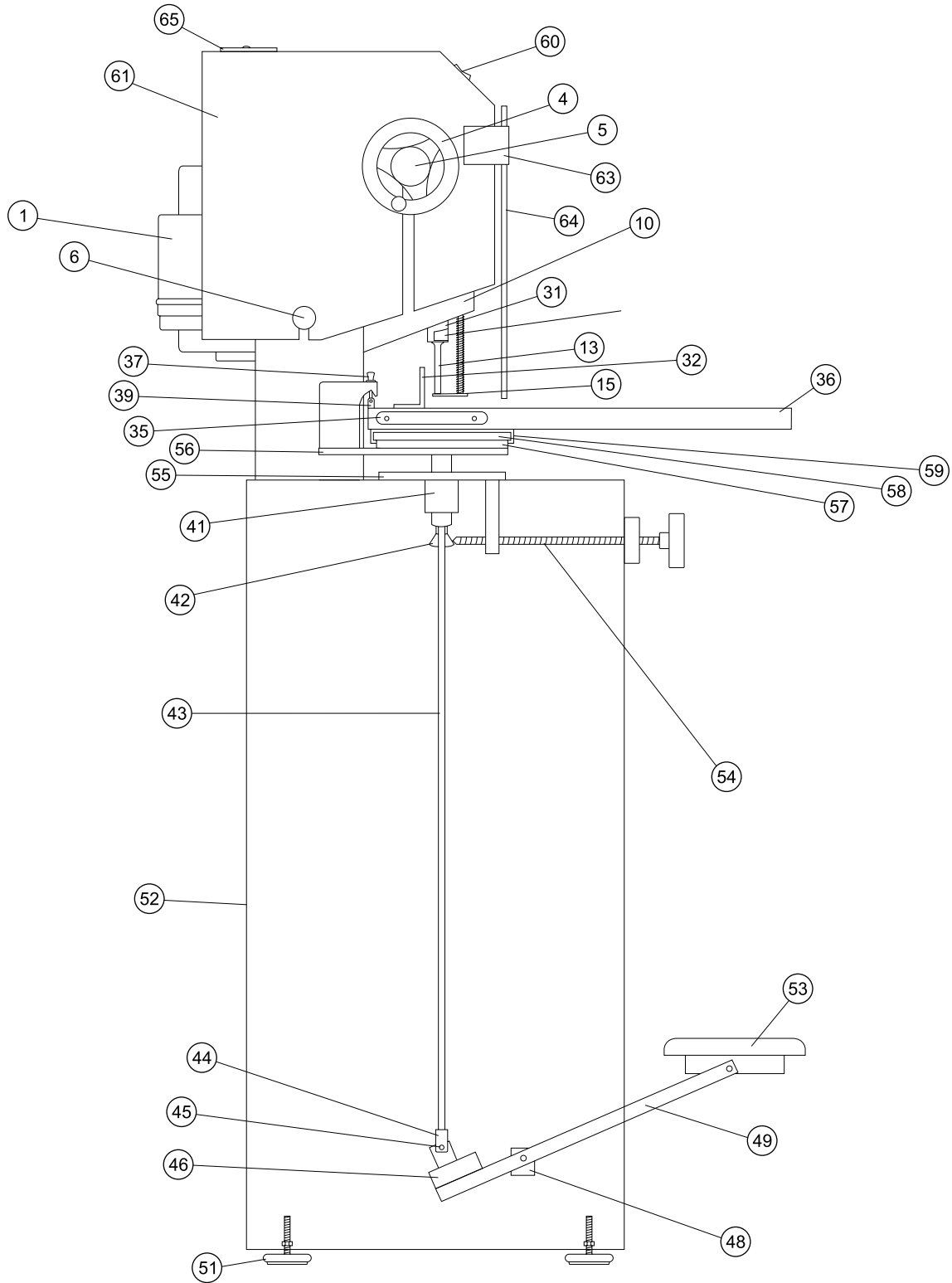

7 - Parts Diagrams

7.2 - Head Assembly

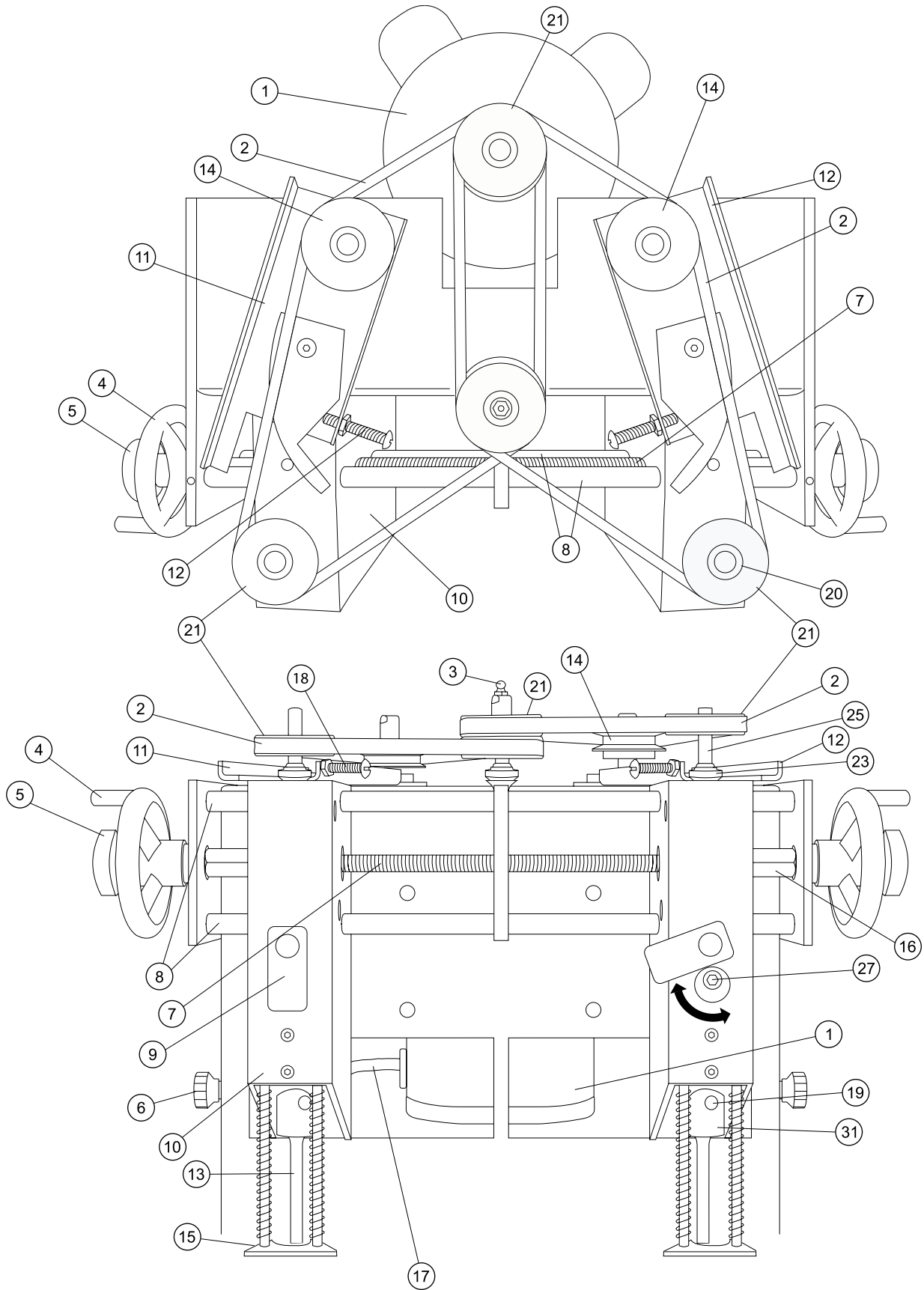

7 - Parts Diagrams

7.3 - Spindle and Chuck Assembly

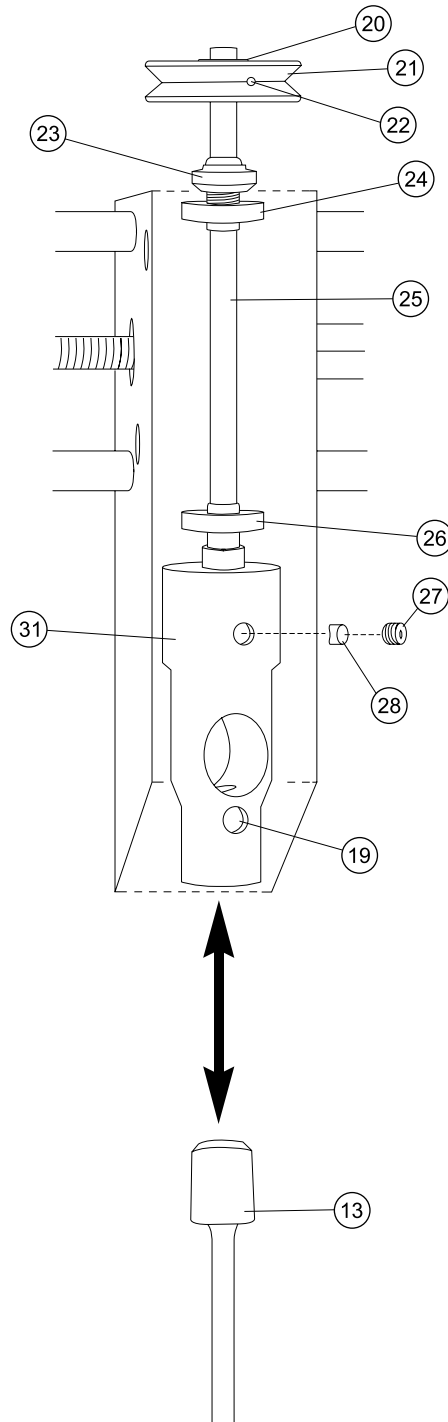

7 - Parts Diagrams

7.4 - Rear View

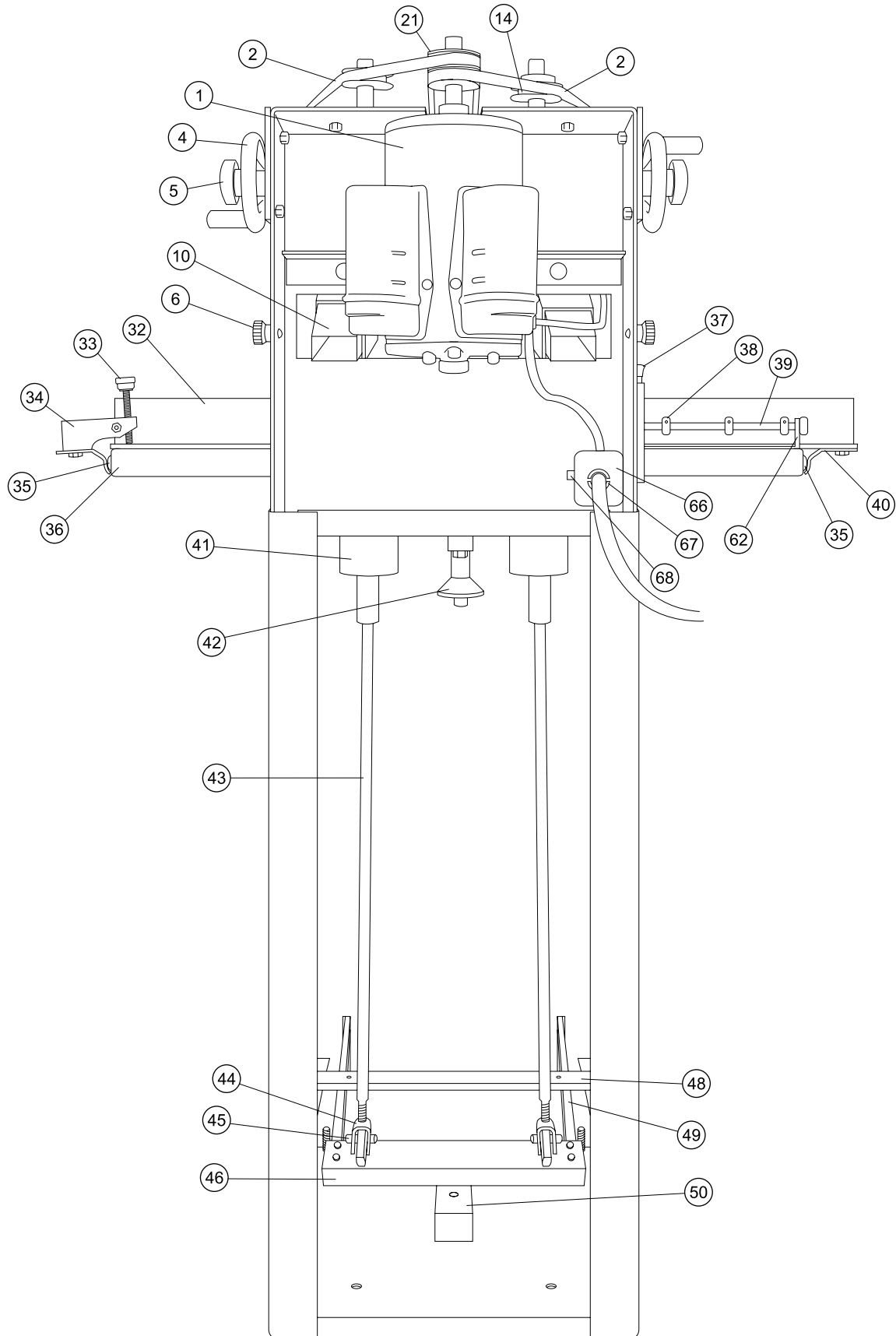

7 - Parts Diagrams

7.5 - Parts List

- ① FMM9-9534: Motor
- ② FMM9-9513: Drive Belt
- ③ N/A
- ④ FMM8-8504: Hand Wheel
- ⑤ FMM8-8508: Hand Wheel Lock Knob
- ⑥ FMM9-9517: Shroud Locking Knob
- ⑦ FMM8-8503: Traverse Lead Screw
- ⑧ FMM8-8502: Traverse Rods
- ⑨ FMM5-5512: Access Cover
- ⑩ FMM5-5506: Housing
- ⑪ FMM2-9500: Left Pivot Channel
- ⑫ FMM2-9502: Right Pivot Channel
- ⑬ Misc: Hollow Drill Bit
- ⑭ FMM9-9506: Idler Pulley
- ⑮ FM6-600A: Pressure Foot Assembly
- ⑯ FMM8-8508: Traverse Stop
- ⑰ FMM9-9516: Cord Set
- ⑱ Cam Adjustment Screw (Belt Adjustment)
- ⑲ Chuck Release Hole
- ⑳ FMM9-9514: Pulley Bushing
- ㉑ FMM9-9505: Pulley
- ㉒ 1/4 x 20 x 3/8 Socket Set Screw
- ㉓ FMM5-5503: Bearing Nut
- ㉔ FMM5-5501: Top Bearing
- ㉕ FMM5-5513: Spindle
- ㉖ FMM5-5502: Bottom Bearing
- ㉗ FMH-5517: Insert Retainer Screw
- ㉘ FMH-5515: Insert
- ㉙ N/A
- ㉚ N/A
- ㉛ FMH-5514: Chuck
- ㉜ FM7-70A: Back Gauge Assembly
- ㉝ FM7-7005: Backgauge Knob
- ㉞ FM7-7003: Clamp Bar
- ㉟ FM4-4003: Side Iron
- ㊱ FM4-4000: Table
- ㊲ FM4-401A: Pedestal Stop Assembly
- ㊳ EBM-47: Stop Collar
- ㊴ FM4-4014: Stop Collar Rod
- ㊵ FM7-7002: Backgauge Clamping Bracket
- ㊶ FM3-3007: Pin Housing
- ㊷ FM3-304A: Vertical Table Travel Stop Assembly
- ㊸ FM2-2006: Push Rod
- ㊹ FM-42: Short Clevis
- ㊺ 50-31: Clevis Pin
- ㊻ FM2-201A: Push Rod Angle Assembly
- ㊼ FM2-200A: Pivot Bar Assembly
- ㊽ FM2-2009: Treadle Bar
- ㊾ FM1-1006: Wood Stop
- ㊿ 50-59: Leveling Feet
- ① FM1-1000: Stand
- ② FM2-2013: Foot Treadle
- ③ FM3-305A: Vertical Stop Adjustment Assembly
- ④ FM3-301A: Die Traverse Assembly
- ⑤ EBM2-1032: Pedestal Support Angle
- ⑥ FM3-3016: Slide Plate Support
- ⑦ FM3-3015: Slide Plate
- ⑧ FM4-4008: Traverse Channel
- ⑨ FM5-5006: On/Off Rocker Switch
- ⑩ FMM9-952A: Shroud Assembly
- ⑪ FM4-4016: Table Traverse Stop
- ⑫ FM-90: Guard Bracket
- ⑬ FM-93: Protective Guard
- ⑭ FM-95: Access Guard
- ⑮ FM-80: Junction Box
- ⑯ FM-86: Strain Relief
- ⑰ FM-82: 15 Amp Fuse